

## Specifications

### ■ Main Specification

●Slewing Speed	2.3min <sup>-1</sup>
●Travel Speed	1.9/1.3km/hr
●Gradeability	40% (22°)

### ■ Lifting Performance

●Max.lifting capacity × working radius	55t × 3.0m
●Max.lifting height	33.0m
●Rope speed (Main and Aux. drums)	100/70m/min
●Rated line pull (Main and Aux. drums)	58.8kN (6t)
●Max line pull (Main and Aux. drums)	156.9kN (16t)
●Free fall system	Standard (Third drum: optional)
●Boom length	11.3m - 34.4m
●Boom extension speed	125sec
●Boom angle	-2° - 80°
●Boom Hoisting Speed	60sec.

### ■ Wire rope

Main winch	20dia.mm × 190m IWRC 6 × Fi (29)
Aux. winch	20dia.mm × 90m IWRC 6 × Fi (29)

### ■ Superstructure

Dive System	Hydraulic
Hydraulic pump	3 axial piston pumps, 3 gear pumps
Counterweight	15.7t
Total operating weight	55.5t
Average ground bearing pressure	71kPa (0.72kgf/cm <sup>2</sup> )

### ■ Engine

Manufacturer	Cummins Inc.
Emission Certification	U.S.EPA Tier3, CARB Tier 3, EU Stage III A
Model	QSB6.7
Type	4-cycle, water-cooled, turbocharged and charge air cooled
Rated Output	179kW/2000min <sup>-1</sup>
Total displacement	6.7L
Fuel tank capacity	225L

### ■ Hydraulic Power System

Power take off	24.5Mpa (250kgf/cm <sup>2</sup> ) × 228L/min 16.1Mpa (164kgf/cm <sup>2</sup> ) × 444L/min
----------------	--

### ■ 3rd drum specification (optional)

Max. lifting capacity × working radius	30t × 5.5m
Rope speed	60m/min.
Wire rope	18dia.mm × 180m IWRC 6 × Fi (29)
Rated line pull	49.0kN (5t)
Max line pull	78.4kN (8t)

Please carefully read the manual before operating machines, and please use it correctly and safely. Photographs appearing in the catalog were taken for publication and may differ in some cases from actual objects. Specifications are subject to change without notice due to technical improvements or modifications.

# KATO



# CCH 550T-3

CCH SERIES CRAWLER CRANE

## All-purpose Telescopic Crane

**KATO** KATO WORKS CO., LTD.

ADDRESS : 9-37, Higashi-ohi 1-chome, Shinagawa-ku, Tokyo, 140-0011 Japan

TEL : +81 3 6433 9594

FAX : +81 3 6433 9636

[www.kato-works.co.jp](http://www.kato-works.co.jp)

**KATO WORKS CO., LTD.**

KH1390KA1907KNK10

# Extraordinary, Reliable Performance, For Lifting and Foundation Work

Longest telescopic boom. Powerful winch. All-round glazing view.  
CCH550T-3 offers a higher level of on-site usability.

## CCH550T-3 5 Major Benefits

- 1 34.4m boom is the longest length among its class for foundation machine. Telescopic boom can be adopted for wide range of working performance.
- 2 Achieved the minimized time and space requirements for on-site boom assembly and disassembly. Self-removal counterweight is available by option.
- 3 Accomplished high speed and safety traveling as well as robust crawler units provide stable traveling.
- 4 Hydraulic system enables independent operation of boom extension/retraction, hoisting/lowering with smooth movement, even for simultaneous operation.
- 5 Large capacity hydraulic PTO (Power Take Off) is capable for various working attachments, such as Vibro hammer, DTH hammer, CFA (Continuous Flight Auger) other various kind of augers.

### General Dimensions

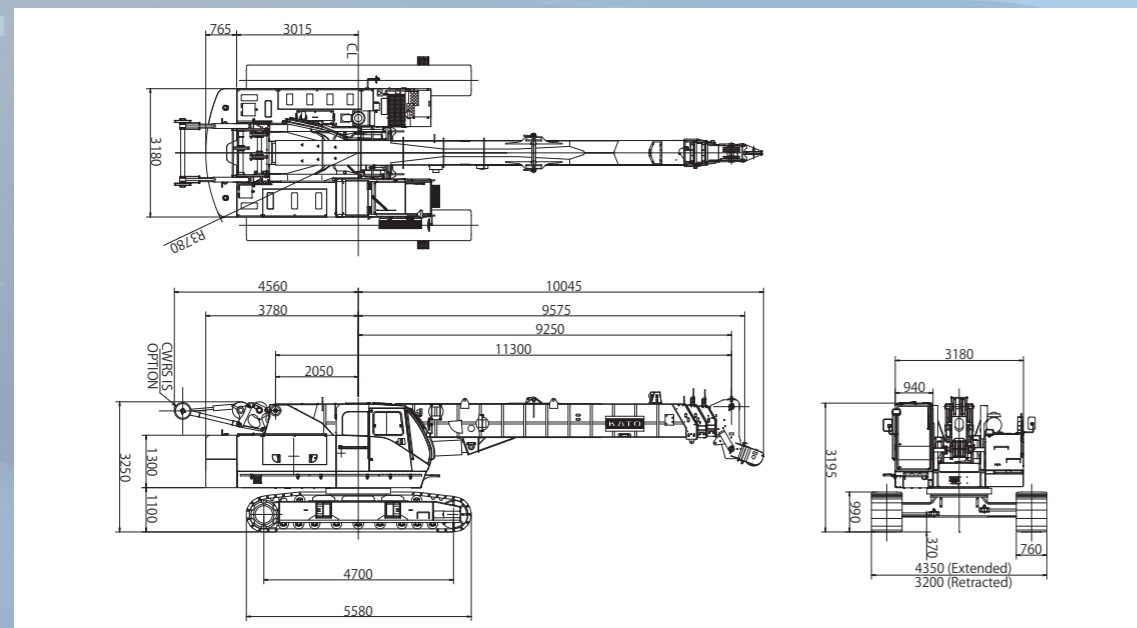

### Working Ranges Diagram

■ Crawlers extended (With 15.7 ton counterweight)

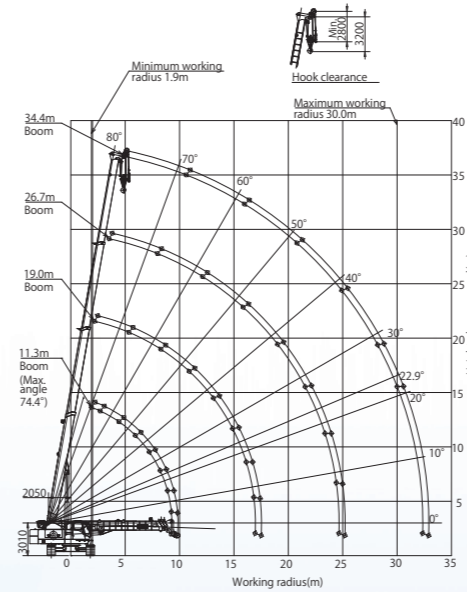

■ Crawlers retracted (With 15.7 ton counterweight)

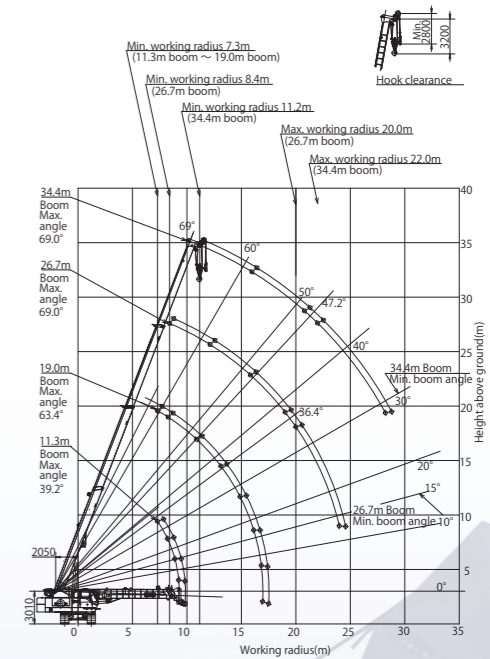

### Rated loads table

■ Crawlers extended (With 15.7 ton counterweight)

(unit : t)

Boom length (m)	11.3		19.0		26.7		34.4		
	Working radius (m)	Load	Boom angle	Load	Boom angle	Load	Boom angle	Load	Boom angle
1.9	55.00	74.4							
2.2	55.00	72.5	30.00	79.9					
3.0	55.00	68.4	30.00	77.5					
3.5	50.00	65.5	30.00	75.9	3.55m × 22.00	79.9			
4.0	46.40	62.6	30.00	74.3	22.00	79.0			
4.5	42.00	59.5	30.00	72.7	22.00	77.9			
5.0	36.35	56.4	30.00	71.1	22.00	76.7	4.9m × 12.00	79.9	
5.5	30.85	53.1	30.00	69.5	5.9m × 22.00	74.7	12.00	78.9	
6.0	26.65	49.6	26.60	67.8	21.70	74.5	12.00	78.1	
6.5	23.35	45.9	23.35	66.2	20.35	73.4	12.00	77.2	
7.0	20.60	41.9	20.65	64.5	18.95	72.2	12.00	76.3	
8.0	15.80	32.4	16.60	61.0	16.15	69.9	8.7m × 12.00	73.4	
9.0	11.40	17.8	13.75	57.4	13.75	67.6	11.65	72.9	
10.0	9.25m × 10.30	0	11.55	53.6	11.55	65.2	10.45	71.1	
12.0			8.50	45.3	8.50	60.3	8.45	67.5	
14.0			6.40	35.3	6.40	55.1	6.85	63.8	
16.0			4.85	21.3	4.95	49.5	5.55	60.0	
18.0			16.95m × 4.10	0	3.70	43.4	4.55	56.0	
20.0					2.70	36.4	3.55	51.7	
22.0					1.85	27.9	2.70	47.3	
24.0					1.15	14.9	2.00	42.4	
26.0					24.65m × 0.95	0	1.45	37.0	
28.0							0.95	30.8	
30.0							0.55	22.9	

■ Crawlers retracted (With 15.7 ton counterweight)

(unit : t)

Boom length (m)	11.3		19.0		26.7		34.4		
	Working radius (m)	Load	Boom angle	Load	Boom angle	Load	Boom angle	Load	Boom angle
7.3	12.00	39.2	12.00	63.4	8.4m × 10.00	69.0			
8.0	12.00	32.4	12.00	61.0	8.9m × 10.00	67.8			
9.0	9.95	17.8	9.85	57.4	9.85	67.6	11.2m × 7.00	69.0	
10.0	9.25m × 9.50	0	8.25	53.6	8.20	65.2	11.6m × 7.00	68.2	
12.0			5.95	45.3	5.90	60.3	6.65	67.5	
14.0			4.30	35.3	4.25	55.1	5.00	63.8	
16.0			2.95	21.3	2.90	49.5	3.75	60.0	
18.0			16.95m × 2.40	0	1.85	43.4	2.75	56.0	
20.0					1.05	36.4	1.90	51.7	
22.0							1.24	47.2	
Limit Angle		0		0		15		30.0	

### Notes

1. All rated loads based on the machine being operated on a firm, level, uniformly supporting surface ground, at any point of 360° around the machine within 75% of tipping load and forward stability factor over 1.15.
2. Working radius is the horizontal distance from the center of rotation to the vertical line through the center of gravity of the load.
3. To determine lifting capacities, the weight of all lifting devices such as hooks must be reduced from the rated loads. When both main hook and auxiliary hook are attached, the weight of both hooks must be reduced.
4. Depending on the number of part lines, rated loads are limited as follows.
5. The standard number of part lines for each boom length is as follows.

55 ton hook	0.80 ton
30 ton hook	0.34 ton
15 ton hook	0.30 ton
6 ton hook	0.12 ton

1 part line	6.0 ton
2 part lines	12.0 ton
3 part lines	16.5 ton
4 part lines	22.0 ton
5 part lines	27.5 ton
6 part lines	33.0 ton
7 part lines	38.5 ton
8 part lines	44.0 ton
9 part lines	49.5 ton
10 part lines	55.0 ton

Boom length (m)	11.3	19.0	26.7	34.4	Top sheave
No. of part lines	10	6	4	4	1