

CCH2000

Fully Hydraulic Crawler Crane

Lifting capacity 200 metric tons



Luffing Jib Crane evolved to equip “Auxiliary Jib”

Luffing Jib Crane

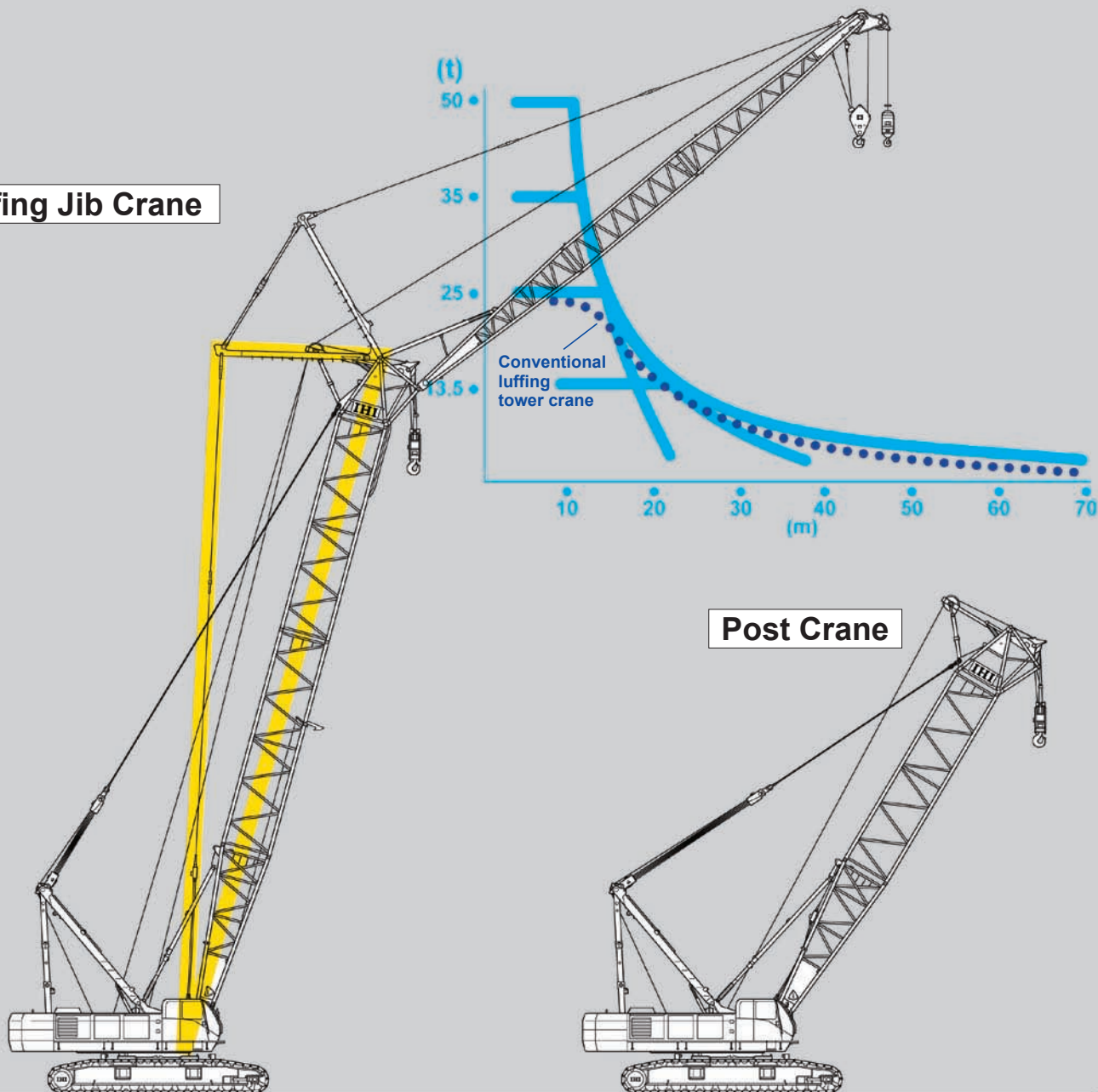

Post Crane

Selections are available from:
1) 50-ton lifting with Post
2) 25-ton lifting with Luffing Jib
3) 13.5-ton lifting with Auxiliary Jib
Simultaneous lifting by Post and Auxiliary Jib is not permitted.

Middle Equalizer for Luffing Jib lifting is tentatively stowed on inner post when the Luffing Jib is dismantled.

General Dimensions

Unit:mm

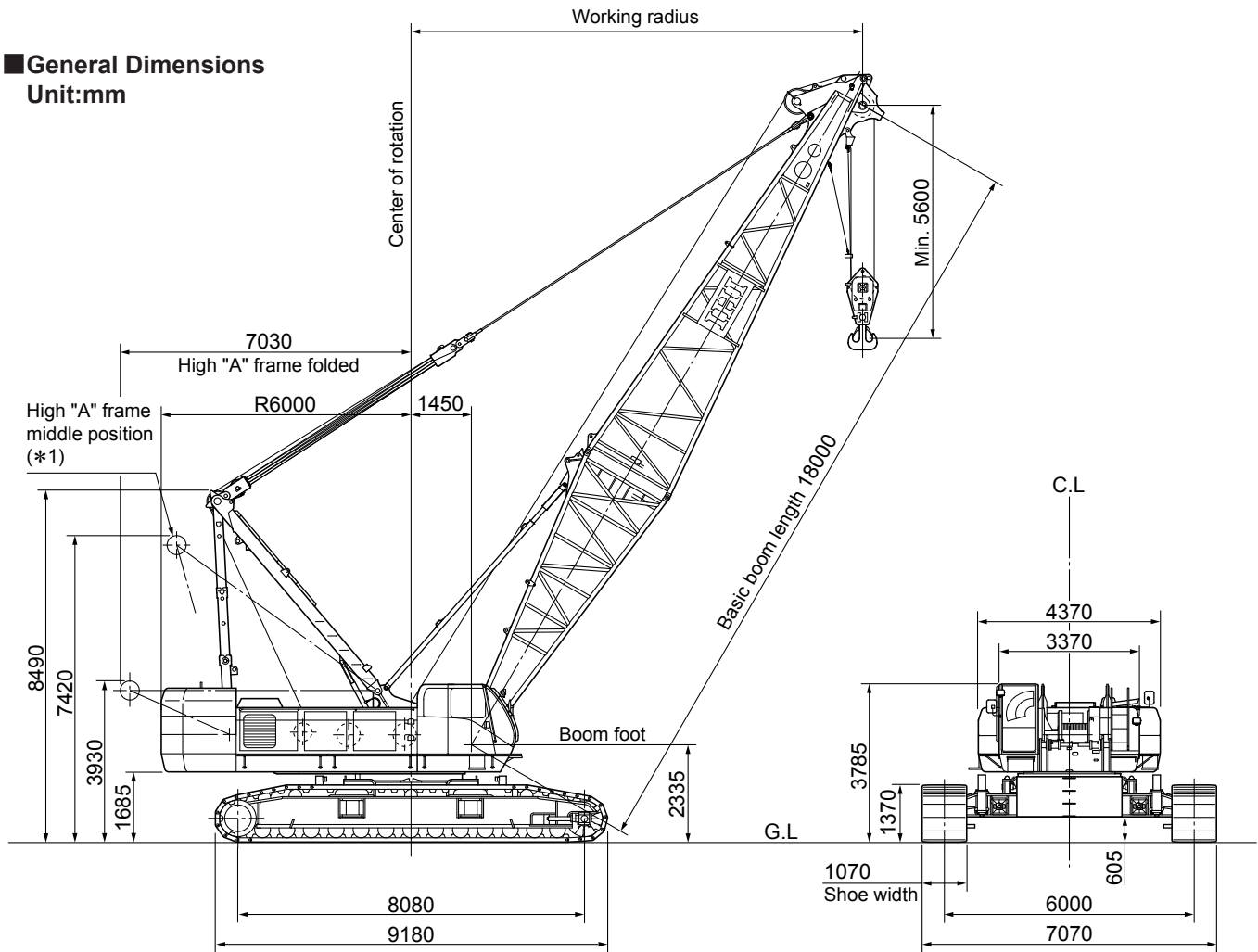

Specifications

Performance	
Swing speed	1.7min ⁻¹ (1.7rpm) [Constant swing speed 0.6min ⁻¹ (0.6rpm)---optional]
Travel speed	※0.9/0.6 km/h
Gradability	30% (16.7°)
Engine	
Make	Cummins Inc.
Model	QSL
Type	Water cooled, 4-cycle, direct fuel injection, turbocharged
Rated output	242kW/2000min ⁻¹
Total piston displacement	8.9L
Fuel tank capacity	400L
Battery	12V x 2pcs.
Main hoist system (Front left axle, also used for hoisting tower jib)	
Hydraulic motor	Variable displacement axial piston type
Reduction gear	Two-stage planetary gear
Hoist drum	Single drum driven independently by hydraulic motor, lebus grooved drum
Clutch	Internal expanding band type
Brake	External contracting band type
Drum lock	Ratchet lock
Aux. hoist system (Rear left axle)	
Hydraulic motor	Variable displacement axial piston type
Reduction gear	Two-stage planetary gear
Hoist drum	Single drum driven independently by hydraulic motor, lebus grooved drum
Clutch	Internal expanding band type
Brake	External contracting band type
Drum lock	Ratchet lock
Boom hoist system (Rear right axle, also used for hoisting tower post)	
Hydraulic motor	Variable displacement axial piston type
Reduction gear	Three-stage planetary gear
Hoist drum	Dual drums driven independently by hydraulic motor, lebus grooved drum
Brake	Wet type multi-disk
Drum lock	Ratchet lock

※The travel speed changes depending on the load.

Standard equipment

- Engine tachometer (with hour meter)
- Hydraulic pressure gauge
- Fuel gauge
- Engine coolant temperature gauge
- Front work lamp (on both sides)
- Operator's room lamp
- Front windshield wiper (with window washer)
- Ceiling wiper (with window washer)
- Sun shade
- Sun-visor
- Storage pouch
- Tool storage
- Reclining operator's seat
- Floor mat
- Steps for operator's cab
- Radio (AM/FM, Cassette)
- Cigarette lighter
- Ashtray
- Rear view mirrors (on both sides)
- Warning horn
- Moment limiter
- Electric fuel pump
- Slewing flashing light
- Slewing warning Buzzer (with voice alarm)
- Travel warning Buzzer (with voice alarm)
- A-frame hoist cylinder
- Bronze tinted glass
- Wire mesh boom walkway (for inner boom)
- Foot rest
- Electrical engine throttle control grip
- Engine throttle pedal
- Ultra low speed control
- Automatic hydraulic assist brake (main and aux.)
- Winch mode selector (main and aux.)
- Rope guide roller on boom back (for outer boom)
- Plug socket (24V)
- Loud speaker
- Winch speed control system (main, aux. and boom hoist)
- Pump power-shift system
- Switch of emergency stop (front and rear)
- Boom foot pin cylinder
- Standard tools for maintenance (details are as per Parts Catalogue)
- Remote controller for jack and crawler expand cylinder

Optional equipment

(1) Base Machine

- Jib drum
- Reeving winch
- Tagline
- Slewing parking break
- Constant speed slewing system
- Slewing mode select switch (free/break)
- Drum rotation indication
- Axle pin cylinder
- Monitor TV (for rear/drum view)
- Monitor TV (for hook load)
- Mirror for drum
- Radio transmitter
- Combustion type heater
- Fire extinguisher
- Room mirror
- Electric fan
- Spark arrester
- Operator gate lock lever
- Tool box (installed in front of operator cabin)
- Name plate (both side of base machine)
- Air conditioner

(2) Light and Instrument

- Yellow rotary light
- Airplane warning light
- Boom point clearance lamp
- Over load outside alarm light (red/yellow/green)
- Work light for drum
- Work light on boom
- Work light for rear direction
- Additional Front work light
- Hand light
- Lift/Depth meter
- Electric clinometer
- Level indicator
- Anemometer

(3) Step and guard

- Catwalk for rear cab
- Catwalk for rear cab (wide type with handrail)
- Handrail for catwalk
- Wire mesh for boom walkway (for insert boom and outer boom)
- Operator cabin roof guard
- Wire rope guard for insert boom
- Hook guard for outer boom (wood or steel pipe)
- Safety guard rope on main boom

(4) Others

- Large size tool box (with caster)
- Sling wire rope (for lifting counter weight or crawler)

Specifications

Max. Lifting capacity x working radius	200metric tons x 5.0m	
Max. boom length	90m	
Max. boom length (main + jib)	103m(72m boom+31m jib)	
Rope speed	Main drum hoist/lowering	* 110~55/55~28m/min
	Aux. drum hoist/lowering	* 110~55/55~28m/min
	Boom drum hoist/lowering	* 32~14m/min x 2
Part line	Hook block capacity x Part line	200ton x 16
	Hook block capacity x Part line	13.5ton x 1
	Boom drum hoist	18
Counterweight	78ton	
Weight for body	16ton	
Total operating weight (with 18m boom)	193ton	
Average ground bearing pressure	103kPa(1.05kgf/cm ²)	

*The rope speed changes depending on the load.

Combination of Boom and Jib (●: Available combination)

Jib length (m)	Boom length (m)												
	18	21	24	27	30	33	36	39	42	45	48	51	54
Auxiliary	●	●	●	●	●	●	●	●	●	●	●	●	●
13	⊗	⊗	⊗	⊗	⊗	⊗	⊗	⊗	⊗	●	●	●	●
19	⊗	⊗	⊗	⊗	⊗	⊗	⊗	⊗	⊗	●	●	●	●
25	⊗	⊗	⊗	⊗	⊗	⊗	⊗	⊗	⊗	●	●	●	●
31	⊗	⊗	⊗	⊗	⊗	⊗	⊗	⊗	⊗	●	●	●	●

Jib length (m)	Boom length (m)											
	57	60	63	66	69	72	75	78	81	84	87	90
Auxiliary	●	●	●	●	●	●	●	●	●	●	●	●
13	●	●	●	●	●	●	●	●	●	●	●	●
19	●	●	●	●	●	●	●	●	●	●	●	●
25	●	●	●	●	●	●	●	●	●	●	●	●
31	●	●	●	●	●	●	●	●	●	●	●	●

Wire Rope

Place of use	Rope diameter (mm)	Guaranteed strength (ton)	Rope type
Main drum	⊗ φ 28	70.2	P•S(19)+39 x P7
Boom hoist	⊗ φ 22	36.3	IWRC6 x P•WS(31)
Boom suspension	⊗ φ 34	104.0	IWRC6 x P•WS(36)
Aux. drum	⊗ φ 28	70.2	P•S(19)+39 x P7
Jib suspension	⊗ φ 28	59.7	IWRC6 x Fi(29)
Jib strut suspension	⊗ φ 31.5	74.9	IWRC6 x Fi(29)

Note: Wire rope length to be determined according to the boom length.

Crane boom composition

The following tables show standard combinations for each boom and jib length.

Boom standard combination

Combination	Boom length (m)												
	18	21	24	27	30	33	36	39	42	45	48	51	54
7.5m inner	1	1	1	1	1	1	1	1	1	1	1	1	1
3.0m insert	—	1	2	1	2	1	1	2	1	1	2	1	1
6.0m insert	—	—	—	1	1	2	1	1	2	1	1	2	1
9.0m insert	—	—	—	—	—	—	1	1	1	2	2	2	3
10.5m outer	1	1	1	1	1	1	1	1	1	1	1	1	1

Combination	Boom length (m)											
	57	60	63	66	69	72	75	78	81	84	87	90
7.5m inner	1	1	1	1	1	1	1	1	1	1	1	1
3.0m insert	2	1	1	2	1	1	2	1	1	2	1	1
6.0m insert	1	2	1	1	2	1	1	2	1	1	2	1
9.0m insert	3	3	4	4	4	5	5	5	6	6	6	7
10.5m outer	1	1	1	1	1	1	1	1	1	1	1	1

Note: Installation of mast is required for boom length exceeding 69m.

Jib standard combination

Combination	Jib length (m)			
	13	19	25	31
6.5m inner	1	1	1	1
6.0m insert	—	1	2	3
6.5m outer	1	1	1	1

*Contact IHI if other combinations required.

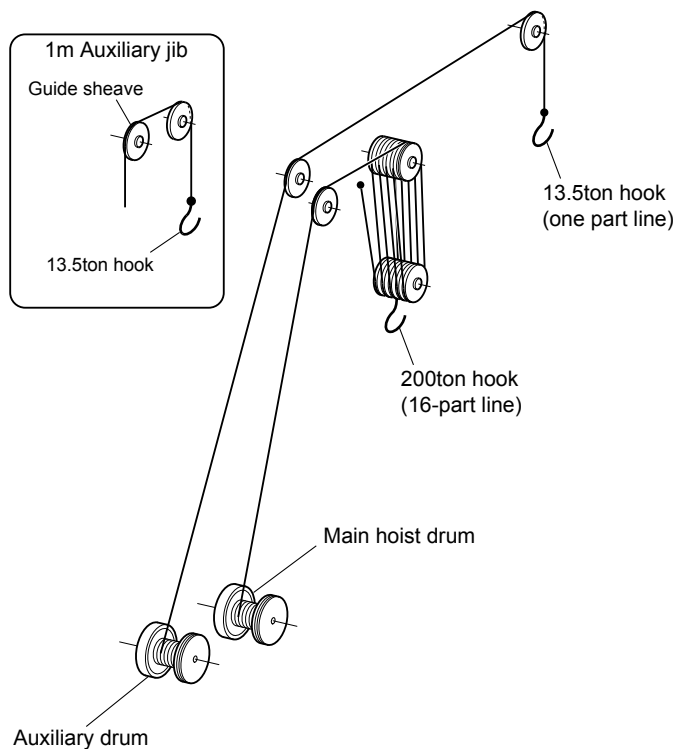
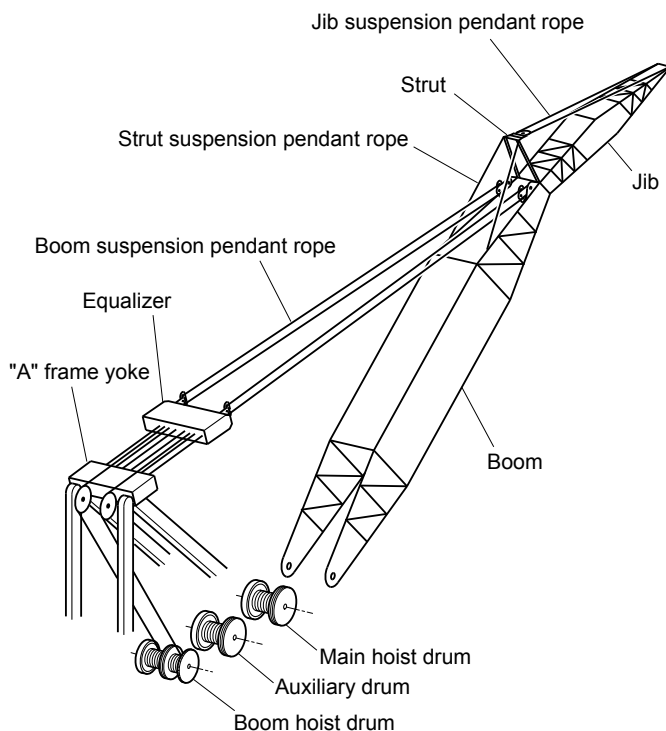

Working range (No load condition)

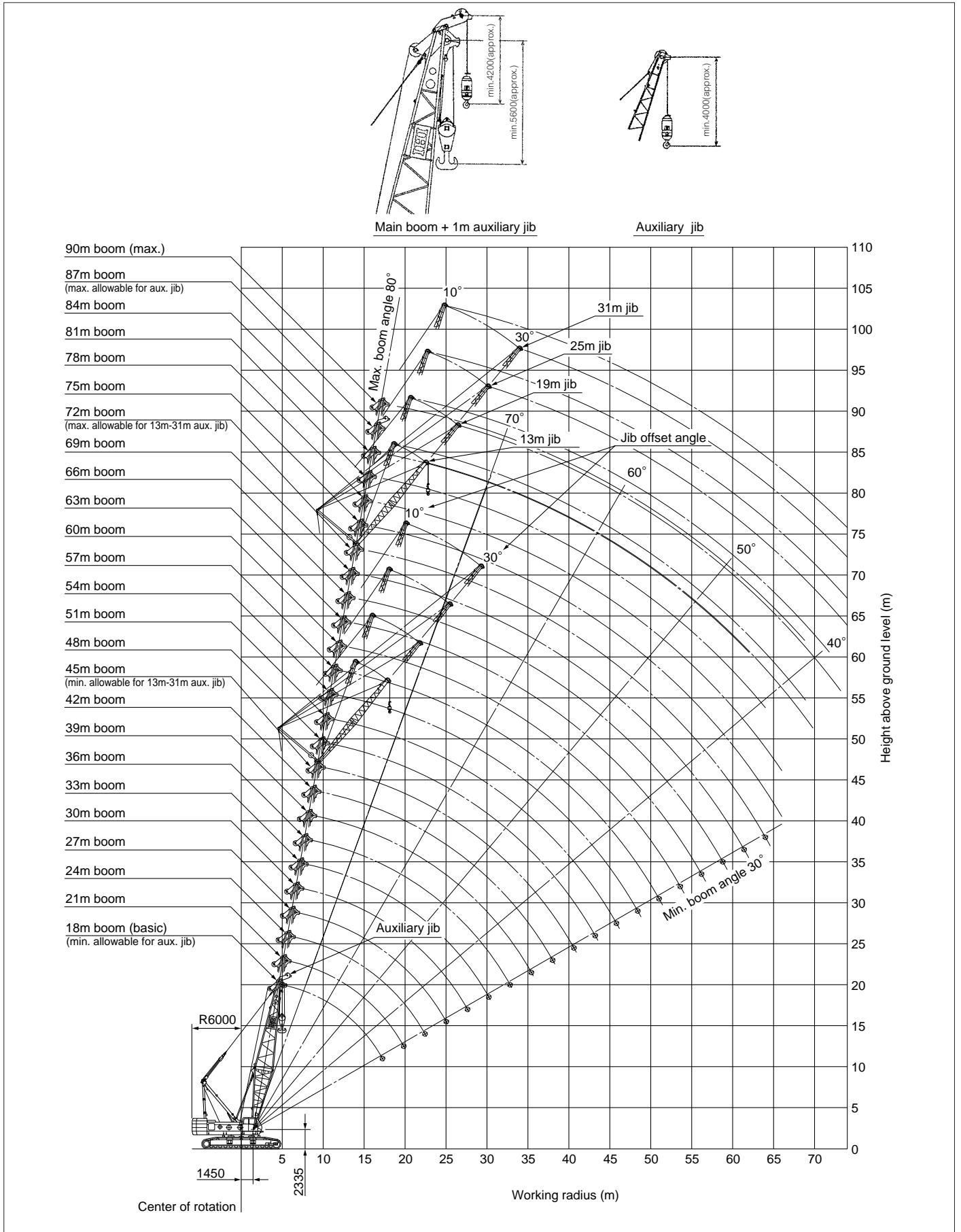

■ Main boom rated lifting loads (78ton counterweight, 16ton weight for body)

(Unit:metric ton)

Boom length (m) Working radius (m)	18.0	21.0	24.0	27.0	30.0	33.0	36.0	39.0	42.0	45.0	48.0	51.0	54.0	57.0	60.0
5.0	5.0m x 200.0	5.6m x 165.0													
6.0	181.0	165.0	6.1m x 150.0	6.6m x 140.0											
7.0	161.9	154.3	146.7	139.1	7.2m x 130.0	7.7m x 118.0									
8.0	136.0	133.5	131.1	128.6	126.1	118.0	8.2m x 108.0	8.7m x 100.0							
9.0	116.6	115.6	114.6	113.6	112.6	108.5	104.4	100.0	9.2m x 94.0	9.8m x 89.0					
10.0	101.3	100.9	100.5	100.0	99.6	97.5	95.4	93.3	91.2	89.0	10.3m x 80.0	10.8m x 75.0	11.3m x 72.0	11.9m x 68.0	
12.0	78.7	78.6	78.5	78.3	78.2	77.5	76.7	76.0	75.2	74.5	72.8	71.1	69.3	67.6	12.4m x 62.0
14.0	62.0	61.8	61.5	61.3	61.0	60.9	60.8	60.7	60.6	60.5	60.1	59.7	59.3	58.9	58.5
16.0	51.0	50.9	50.8	50.6	50.5	50.4	50.3	50.2	50.1	50.0	49.9	49.8	49.7	49.6	49.5
18.0	17.2m x 46.4	43.3	43.2	43.0	42.9	42.8	42.7	42.7	42.6	42.5	42.4	42.3	42.2	42.1	42.0
20.0		19.8m x 38.4	37.8	37.6	37.5	37.4	37.3	37.1	37.0	36.9	36.8	36.7	36.6	36.5	36.4
22.0			33.4	33.1	32.7	32.6	32.5	32.4	32.3	32.2	32.1	32.0	31.8	31.7	31.6
24.0			22.4m x 32.7	29.5	29.2	29.1	29.0	28.9	28.8	28.7	28.6	28.5	28.3	28.2	28.1
26.0				25.0m x 28.0	26.4	26.3	26.2	26.0	25.9	25.8	25.7	25.5	25.4	25.2	25.1
28.0				27.6m x 24.5	23.9	23.7	23.6	23.4	23.3	23.1	23.0	22.8	22.7	22.5	
30.0					21.8	21.7	21.5	21.4	21.2	21.0	20.9	20.7	20.6	20.4	
32.0					30.2m x 21.7	19.9	19.7	19.6	19.5	19.3	19.1	19.0	18.8	18.6	
34.0						32.8m x 19.2	18.1	18.0	17.9	17.7	17.5	17.4	17.2	17.0	
36.0							35.4m x 17.1	16.6	16.5	16.3	16.1	16.0	15.8	15.6	
38.0								38.0m x 15.4	15.3	15.1	14.9	14.7	14.5	14.3	
40.0									14.3	14.1	13.9	13.6	13.4	13.2	
42.0									40.6m x 14.0	13.1	12.9	12.6	12.4	12.2	
44.0										43.2m x 12.5	11.9	11.7	11.5	11.3	
46.0											45.8m x 11.2	10.9	10.7	10.5	
48.0												10.2	10.0	9.8	
50.0												48.4m x 10.0	9.3	9.1	
52.0													51.0m x 8.9	8.4	
54.0														53.6m x 8.0	

Boom length (m) Working radius (m)	63.0	66.0	69.0	72.0	75.0	78.0	81.0	84.0	87.0	90.0
12.0	12.9m x 56.0	13.4m x 50.0	13.9m x 47.0							
14.0	54.2	48.1	47.0	14.5m x 42.0	15.0m x 37.5	15.5m x 34.0				
16.0	47.1	44.1	43.3	41.8	37.5	34.0	16.0m x 30.5	16.5m x 28.0	17.0m x 25.0	17.5m x 23.0
18.0	41.2	40.2	40.1	38.0	35.6	33.3	30.5	27.0	25.0	22.6
20.0	36.3	35.9	35.7	35.6	33.4	30.4	28.5	25.7	23.5	20.6
22.0	31.5	31.4	31.3	31.2	31.1	28.5	26.4	24.5	21.8	19.0
24.0	28.0	27.8	27.7	27.6	27.5	27.3	25.0	22.7	20.3	18.0
26.0	25.0	24.8	24.5	24.3	24.0	23.8	23.5	21.2	19.1	16.8
28.0	22.4	22.2	22.0	21.9	21.8	21.6	21.5	19.8	17.8	15.6
30.0	20.3	20.1	19.9	19.8	19.7	19.6	19.5	18.6	16.7	14.5
32.0	18.4	18.2	18.0	17.9	17.8	17.7	17.6	17.5	15.7	13.6
34.0	16.8	16.6	16.4	16.3	16.2	16.1	16.0	15.8	14.7	12.8
36.0	15.4	15.2	15.0	14.9	14.8	14.6	14.5	14.3	13.9	12.0
38.0	14.1	13.9	13.7	13.6	13.5	13.4	13.3	13.0	12.8	11.3
40.0	13.0	12.8	12.6	12.5	12.4	12.3	12.2	11.9	11.7	10.6
42.0	12.0	11.8	11.6	11.5	11.4	11.3	11.2	10.8	10.6	10.1
44.0	11.1	10.9	10.7	10.6	10.5	10.4	10.3	9.8	9.6	9.2
46.0	10.3	10.1	9.9	9.8	9.7	9.5	9.4	8.9	8.6	8.3
48.0	9.6	9.4	9.1	8.9	8.8	8.6	8.4	8.0	7.8	7.4
50.0	8.9	8.7	8.5	8.4	8.2	8.1	7.9	7.4	7.0	6.7
52.0	8.3	8.1	7.8	7.7	7.5	7.4	7.2	6.8	6.3	6.0
54.0	7.7	7.5	7.3	7.2	7.0	6.9	6.7	6.2	5.7	5.4
56.0	7.2	7.0	6.8	6.6	6.5	6.3	6.1	5.7	5.2	4.8
58.0	56.2m x 7.1	6.5	6.3	6.1	6.0	5.8	5.6	5.2	4.6	4.2
60.0		58.8m x 6.3	5.8	5.6	5.5	5.3	5.1	4.7	4.2	3.6
62.0			61.4m x 5.5	5.2	5.0	4.8	4.6	4.3	3.6	3.1
64.0				64.0m x 4.8	4.6	4.4	4.2	3.8	3.2	2.7
66.0					4.2	4.0	3.8	3.4	2.7	2.3
68.0					66.2m x 4.0	3.2	3.0	2.5	2.3	2.0
70.0							2.5	2.0		

Notes

- Above rated loads are based on the machine being operated on firm level ground, within 78% of tipping load at any point of 360° around the machine with forward stability factor of over 1.15.
- Working radius is horizontal distance from center of rotation to a vertical line through the center of gravity of the load.
- The weight of the slings, hook block(s) and auxiliary lifting devices must be considered to be a part of the load.
Hook block weight:
200ton hook block...2.70ton 150ton hook block...2.40ton
100ton hook block...1.40ton 60ton hook block...1.20ton
50ton hook block...1.00ton 30ton hook block...1.00ton
13.5ton hook block...0.60ton
- Jib boom can be fitted to main boom in the following combinations.

Jib length(m)	Auxiliary	13.0	19.0	25.0	31.0
Boom length(m)		18.0~87.0	45.0~72.0	45.0~72.0	45.0~72.0
- When jib boom is fitted actual loads that can be lifted with main hook block should be reduced according to the below table (the weights include auxiliary hook block).

Jib length(m)	Auxiliary	13.0	19.0	25.0	31.0
Weight to be deducted(ton)		0.8	3.5	4.0	4.9
- High "A" Frame should be extended before working. Extend the "A" frame to the highest position when there is no mast. Extend the "A" frame to the mid-position when there is a mast.
- Depending on the number of part lines, rated lifting load is limited as follows:

1Part line...up to 13.5ton	2Part line...up to 25.0ton
3Part line...up to 37.5ton	4Part line...up to 50.0ton
5Part line...up to 62.5ton	6Part line...up to 75.0ton
7Part line...up to 87.5ton	8Part line...up to 100.0ton
9Part line...up to 112.5ton	10Part line...up to 125.0ton
11Part line...up to 137.5ton	12Part line...up to 150.0ton
13Part line...up to 162.5ton	14Part line...up to 175.0ton
15Part line...up to 187.5ton	16Part line...up to 200.0ton
- Always use a mast for boom length of 69m or over. Carefully follow the instruction manual concerning installation of pendant rope.
- Rated loads shown in bold lines are based on structural strength factors.

■ 1m aux. jib rated lifting loads (78ton counterweight, 16ton weight for body)

(Unit: metric ton)

Boom length (m) Working radius (m)	18.0	21.0	24.0	27.0	30.0	33.0	36.0	39.0	42.0	45.0	48.0	51.0	54.0	57.0	60.0
5.0	5.9m x 13.5														
6.0	13.5	6.4m x 13.5													
7.0	13.5	13.5	7.0m x 13.5	7.5m x 13.5											
8.0	13.5	13.5	13.5	13.5	8.0m x 13.5	8.5m x 13.5									
9.0	13.5	13.5	13.5	13.5	13.5	13.5	9.0m x 13.5	9.6m x 13.5							
10.0	13.5	13.5	13.5	13.5	13.5	13.5	13.5	13.5	10.1m x 13.5	10.5m x 13.5	11.1m x 13.5	11.6m x 13.5			
12.0	13.5	13.5	13.5	13.5	13.5	13.5	13.5	13.5	13.5	13.5	13.5	13.5	12.2m x 13.5	12.7m x 13.5	13.2m x 13.5
14.0	13.5	13.5	13.5	13.5	13.5	13.5	13.5	13.5	13.5	13.5	13.5	13.5	13.5	13.5	13.5
16.0	13.5	13.5	13.5	13.5	13.5	13.5	13.5	13.5	13.5	13.5	13.5	13.5	13.5	13.5	13.5
18.0	13.5	13.5	13.5	13.5	13.5	13.5	13.5	13.5	13.5	13.5	13.5	13.5	13.5	13.5	13.5
20.0	18.8m x 13.5	13.5	13.5	13.5	13.5	13.5	13.5	13.5	13.5	13.5	13.5	13.5	13.5	13.5	13.5
22.0		21.4m x 13.5	13.5	13.5	13.5	13.5	13.5	13.5	13.5	13.5	13.5	13.5	13.5	13.5	13.5
24.0			24.0m x 13.5	13.5	13.5	13.5	13.5	13.5	13.5	13.5	13.5	13.5	13.5	13.5	13.5
26.0				13.5	13.5	13.5	13.5	13.5	13.5	13.5	13.5	13.5	13.5	13.5	13.5
28.0				26.6m x 13.5	13.5	13.5	13.5	13.5	13.5	13.5	13.5	13.5	13.5	13.5	13.5
30.0					29.2m x 13.5	13.5	13.5	13.5	13.5	13.5	13.5	13.5	13.5	13.5	13.5
32.0						31.7m x 13.5	13.5	13.5	13.5	13.5	13.5	13.5	13.5	13.5	13.5
34.0							13.5	13.5	13.5	13.5	13.5	13.5	13.5	13.5	13.5
36.0							34.3m x 13.5	13.5	13.5	13.5	13.5	13.5	13.5	13.5	13.5
38.0								36.9m x 13.5	13.5	13.5	13.5	13.5	13.5	13.5	13.5
40.0									39.5m x 13.5	13.5	13.3	13.1	12.8	12.6	12.4
42.0										12.5	12.3	12.1	11.8	11.6	11.4
44.0										42.1m x 12.5	11.3	11.1	10.9	10.7	10.5
46.0											44.7m x 11.0	10.3	10.1	9.9	9.7
48.0												47.3m x 9.8	9.4	9.2	9.0
50.0													49.9m x 8.7	8.5	8.3
52.0														7.8	7.6
54.0														52.5m x 7.7	7.0
56.0															55.1m x 6.8

Boom length (m) Working radius (m)	63.0	66.0	69.0	72.0	75.0	78.0	81.0	84.0	87.0
12.0	13.7m x 13.5								
14.0	13.5	14.2m x 13.5	14.8m x 13.5	15.3m x 13.5	15.8m x 13.5				
16.0	13.5	13.5	13.5	13.5	13.5	16.3m x 13.5	16.9m x 13.5	17.4m x 13.5	17.9m x 13.5
18.0	13.5	13.5	13.5	13.5	13.5	13.5	13.5	13.5	13.5
20.0	13.5	13.5	13.5	13.5	13.5	13.5	13.5	13.5	13.5
22.0	13.5	13.5	13.5	13.5	13.5	13.5	13.5	13.5	13.5
24.0	13.5	13.5	13.5	13.5	13.5	13.5	13.5	13.5	13.5
26.0	13.5	13.5	13.5	13.5	13.5	13.5	13.5	13.5	13.5
28.0	13.5	13.5	13.5	13.5	13.5	13.5	13.5	13.5	13.5
30.0	13.5	13.5	13.5	13.5	13.5	13.5	13.5	13.5	13.5
32.0	13.5	13.5	13.5	13.5	13.5	13.5	13.5	13.5	13.5
34.0	13.5	13.5	13.5	13.5	13.5	13.5	13.5	13.5	13.5
36.0	13.5	13.5	13.5	13.5	13.5	13.5	13.5	13.5	13.1
38.0	13.3	13.1	12.9	12.8	12.7	12.6	12.5	12.2	12.0
40.0	12.2	12.0	11.8	11.7	11.6	11.5	11.4	11.1	10.9
42.0	11.2	11.0	10.8	10.7	10.6	10.5	10.4	10.0	9.8
44.0	10.3	10.1	9.9	9.8	9.7	9.6	9.5	9.0	8.8
46.0	9.5	9.3	9.1	9.0	8.9	8.7	8.6	8.1	7.8
48.0	8.8	8.6	8.3	8.1	8.0	7.8	7.6	7.2	7.0
50.0	8.1	7.9	7.7	7.6	7.4	7.3	7.1	6.6	6.2
52.0	7.5	7.3	7.0	6.9	6.7	6.6	6.4	6.0	5.5
54.0	6.9	6.7	6.5	6.4	6.2	6.1	5.9	5.4	4.9
56.0	6.4	6.2	6.0	5.8	5.7	5.5	5.3	4.9	4.4
58.0	57.7m x 5.9	5.7	5.5	5.3	5.2	5.0	4.8	4.4	3.8
60.0		5.1	5.0	4.8	4.7	4.5	4.3	3.9	3.4
62.0		60.3m x 9.0	4.6	4.4	4.2	4.0	3.8	3.5	2.8
64.0			62.9m x 4.4	4.0	3.8	3.6	3.4	3.0	2.4
66.0				65.5m x 3.6	3.4	3.2	3.0	2.6	
68.0						2.4	2.2		

Notes

- Above rated loads are based on the machine being operated on firm level ground, within 78% of tipping load at any point of 360° around the machine with forward stability factor of over 1.15.
- Working radius is horizontal distance from center of rotation to a vertical line through the center of gravity of the load.
- When the main hook block is installed, the lifting loads of jib must be reduced by the weight of hook block (main and jib) and other lifting devices.
 200ton hook block...2.70ton
 150ton hook block...2.40ton
 100ton hook block...1.40ton
 60ton hook block...1.20ton
 50ton hook block...1.00ton
 30ton hook block...1.00ton
 13.5ton hook block...0.60ton
- Boom lengths for auxiliary jib attachment are 18.0m-87.0m.
- Always extend the "A" frame during operation.
- Use the 1m auxiliary jib for crane operations only. Do not use for bucket operations.
- Rated loads for the 1m auxiliary jib are based on structural strength.

Aux. jib rated lifting loads (78ton counterweight, 16ton weight for body)

(Unit:metric ton)

Boom length (m)	45.0								48.0								51.0									
Jib length (m)	13.0		19.0		25.0		31.0		13.0		19.0		25.0		31.0		13.0		19.0		25.0		31.0			
Offset angle	10°		30°		10°		30°		10°		30°		10°		30°		10°		30°		10°		30°			
Working radius (m)	10°	30°	10°	30°	10°	30°	10°	30°	10°	30°	10°	30°	10°	30°	10°	30°	10°	30°	10°	30°	10°	30°	10°	30°		
14.0	14.1mx 13.5		15.5mx 12.0							14.6mx 13.5								15.1mx 13.5								
16.0	13.5		12.0							13.5		16mx 12.0						13.5		16.6mx 12.0						
18.0	13.5	18mx 13.0	12.0		18.2mx 8.0		19.7mx 3.5		13.5	18.5mx 13.0	12.0		18.7mx 8.0				13.5	19mx 13.0	12.0		19.2mx 8.0					
20.0	13.5	13.0	12.0		21.3mx 8.0	8.0		3.5	13.5	13.0	12.0		21.8mx 8.0	8.0		20.2mx 3.5		13.5	13.0	12.0		8.0		20.7mx 3.5		
22.0	13.5	13.0	12.0	8.0	8.0	8.0		3.5	13.5	13.0	12.0	8.0	8.0	8.0		3.5		13.5	13.0	12.0		22.4mx 8.0	8.0		3.5	
24.0	13.5	13.0	12.0	8.0	8.0	8.0	25.7mx 6.0	3.5	13.5	13.0	12.0	8.0	8.0		3.5		13.5	13.0	12.0	8.0	8.0			3.5		
26.0	13.5	13.0	12.0	8.0	8.0	8.0	6.0	3.5	13.5	13.0	12.0	8.0	8.0	26.2mx 6.0	3.5		13.5	13.0	12.0	8.0	8.0	26.7mx 6.0		3.5		
28.0	13.5	13.0	12.0	8.0	8.0	8.0	6.0	3.5	29mx 3.0	13.5	13.0	12.0	8.0	8.0	6.0	3.5	29.6mx 3.0	13.5	13.0	12.0	8.0	8.0	6.0	3.5		
30.0	13.5	13.0	12.0	8.0	8.0	8.0	6.0	3.5	3.0	13.5	13.0	12.0	8.0	8.0	6.0	3.5	3.0	13.5	13.0	12.0	8.0	8.0	6.0	3.5	30.1mx 3.0	
32.0	13.5	13.0	12.0	8.0	8.0	8.0	6.0	3.5	3.0	13.5	13.0	12.0	8.0	8.0	6.0	3.5	3.0	13.5	13.0	12.0	8.0	8.0	6.0	3.5	3.0	
34.0	13.5	13.0	12.0	8.0	8.0	8.0	6.0	3.5	3.0	13.5	13.0	12.0	8.0	8.0	6.0	3.5	3.0	13.5	13.0	12.0	8.0	8.0	6.0	3.5	3.0	
36.0	13.5	13.0	12.0	8.0	8.0	8.0	6.0	3.5	3.0	13.5	13.0	12.0	8.0	8.0	6.0	3.5	3.0	13.5	13.0	12.0	8.0	8.0	6.0	3.5	3.0	
38.0	13.5	13.0	12.0	8.0	8.0	8.0	6.0	3.5	3.0	13.5	13.0	12.0	8.0	8.0	6.0	3.5	3.0	13.5	13.0	12.0	8.0	8.0	6.0	3.5	3.0	
40.0	13.5	13.0	12.0	8.0	8.0	8.0	6.0	3.5	3.0	13.5	13.0	12.0	8.0	8.0	6.0	3.5	3.0	13.5	13.0	12.0	8.0	8.0	6.0	3.5	3.0	
42.0	13.3	13.0	12.0	8.0	8.0	8.0	6.0	3.5	3.0	13.1	13.0	12.0	8.0	8.0	6.0	3.5	3.0	12.9	12.9	12.0	8.0	8.0	6.0	3.5	3.0	
44.0	12.3	12.3	12.0	8.0	8.0	8.0	6.0	3.5	3.0	12.1	12.1	12.0	8.0	8.0	6.0	3.5	3.0	11.9	11.9	11.9	8.0	8.0	6.0	3.5	3.0	
46.0	11.5	11.5	11.5	8.0	8.0	8.0	6.0	3.5	3.0	11.3	11.3	11.3	8.0	8.0	6.0	3.5	3.0	11.1	11.1	11.1	8.0	8.0	6.0	3.5	3.0	
48.0	10.7	10.7	10.7	8.0	8.0	8.0	6.0	3.5	3.0	10.5	10.5	10.5	8.0	8.0	6.0	3.5	3.0	10.3	10.3	10.3	8.0	8.0	6.0	3.5	3.0	
50.0	10.0	10.0	10.0	8.0	8.0	8.0	6.0	3.5	3.0	9.8	9.8	9.8	8.0	8.0	6.0	3.5	3.0	9.6	9.6	9.6	8.0	8.0	6.0	3.5	3.0	
52.0	9.3	9.3	9.3	8.0	8.0	8.0	6.0	3.5	3.0	9.1	9.1	9.1	8.0	8.0	6.0	3.5	3.0	9.0	9.0	9.0	8.0	8.0	6.0	3.5	3.0	
54.0	53.3mx 8.9	8.7	8.7	8.0	8.0	8.0	6.0	3.5	3.0	8.5	8.5	8.5	8.0	8.0	6.0	3.5	3.0	8.4	8.4	8.4	8.0	8.0	6.0	3.5	3.0	
56.0		54.2mx 8.7	8.2	8.0	8.0	8.0	6.0	3.5	3.0	59.9mx 8.1	8.0	8.0	8.0	8.0	6.0	3.5	3.0	7.9	7.9	7.9	7.9	7.9	7.9	6.0	3.5	3.0
58.0			7.7	7.7	7.7	6.0	3.5	3.0		56.8mx 7.8	7.5	7.5	7.5	6.0	3.5	3.0	7.4	7.4	7.4	7.4	7.4	7.4	6.0	3.5	3.0	
60.0			58.8mx 7.5	7.2	7.2	6.0	3.5	3.0	60mx 3.5	60mx 3.0			7.0	7.0	7.0	6.0	3.5	3.0	58.5mx 7.2	59.4mx 7.0	6.8	6.8	6.8	6.0	3.5	3.0
62.0				60.2mx 7.2	6.7	6.0						61.4mx 6.7	6.5	6.5	6.0			62mx 3.5	62mx 3.0		6.3	6.3	6.3	6.0	3.5	3.0
64.0					64mx 6.3	64mx 6.0							62.8mx 6.3	64mx 6.1	64mx 6.0					64mx 5.9	5.9	5.9	5.9	64mx 3.5	64mx 3.0	
66.0																					65.4mx 5.6	66mx 5.5	66mx 5.5			

Boom length (m)	54.0								57.0																
Jib length (m)	13.0		19.0		25.0		31.0		13.0		19.0		25.0		31.0										
Offset angle	10°		30°		10°		30°		10°		30°		10°		30°										
Working radius (m)	10°	30°	10°	30°	10°	30°	10°	30°	10°	30°	10°	30°	10°	30°	10°	30°									
14.0	15.6mx 13.5																								
16.0	13.5		17.1mx 12.0						16.1mx 13.5		17.6mx 12.0														
18.0	13.5	19.5mx 13.0	12.0		19.8mx 8.0				13.5		12.0														
20.0	13.5	13.0	12.0		8.0		21.3mx 3.5		13.5	20mx 13.0	12.0		20.3mx 8.0		21.8mx 3.5										
22.0	13.5	13.0	12.0		22.9mx 8.0	8.0		3.5	13.5	13.0	12.0		23.4mx 8.0	8.0		3.5									
24.0	13.5	13.0	12.0	8.0	8.0	8.0		3.5	13.5	13.0	12.0	8.0	8.0		3.5										
26.0	13.5	13.0	12.0	8.0	8.0	8.0	27.2mx 6.0	3.5	13.5	13.0	12.0	8.0	8.0	27.7mx 6.0	3.5										
28.0	13.5	13.0	12.0	8.0	8.0	8.0	6.0	3.5	13.5	13.0	12.0	8.0	8.0	6.0	3.5										
30.0	13.5	13.0	12.0	8.0	8.0	8.0	6.0	3.5	30.6mx 3.0	13.5	13.0	12.0	8.0	8.0	6.0	3.5	31.1mx 3.0								
32.0	13.5	13.0	12.0	8.0	8.0	8.0	6.0	3.5	3.0	13.5	13.0	12.0	8.0	8.0	6.0	3.5	3.0								
34.0	13.5	13.0	12.0	8.0	8.0	8.0	6.0	3.5	3.0	13.5	13.0	12.0	8.0	8.0	6.0	3.5	3.0								
36.0	13.5	13.0	12.0	8.0	8.0	8.0	6.0	3.5	3.0	13.5	13.0	12.0	8.0	8.0	6.0	3.5	3.0								
38.0	13.5	13.0	12.0	8.0	8.0	8.0	6.0	3.5	3.0	13.5	13.0	12.0	8.0	8.0	6.0	3.5	3.0								
40.0	13.5	13.0	12.0	8.0	8.0	8.0	6.0	3.5	3.0	13.4	13.0	12.0	8.0	8.0	6.0	3.5	3.0								
42.0	12.6	12.6	12.0	8.0	8.0	8.0	6.0	3.5	3.0	12.4	12.4	12.0	8.0	8.0	6.0	3.5	3.0								
44.0	11.7	11.7	11.7	8.0	8.0	8.0	6.0	3.5	3.0	11.5	11.5	11.5	8.0	8.0	6.0	3.5	3.0								
46.0	10.9	10.9	10.9	8.0	8.0	8.0	6.0	3.5	3.0	10.7	10.7	10.7	8.0	8.0	6.0	3.5	3.0								
48.0	10.2	10.2	10.2	8.0	8.0	8.0	6.0	3.5	3.0	10.0	10.0	10.0	8.0	8.0	6.0	3.5	3.0								
50.0	9.5	9.5	9.5	8.0	8.0	8.0	6.0	3.5	3.0	9.3	9.3	9.3	8.0	8.0	6.0	3.5	3.0								
52.0	8.8	8.8	8.8	8.0	8.0	8.0	6.0	3.5	3.0	8.6	8.6	8.6	8.0	8.0	6.0	3.5	3.0								
54.0	8.2	8.2	8.2	8.0	8.0	8.0	6.0	3.5	3.0	8.0	8.0	8.0	8.0	8.0	6.0	3.5	3.0								
56.0	7.7	7.7	7.7	7.7	7.7	6.0	3.5	3.0	7.5	7.5	7.5	7.5	7.5	6.0	3.5	3.0									
58.0	7.2	7.2	7.2	7.2	7.2	6.0	3.5	3.0	7.0	7.0	7.0	7.0	7.0	6.0	3.5	3.0									
60.0	6.6	6.6	6.6	6.6	6.6	6.0	3.5	3.0	6.5	6.5	6.5	6.5	6.5	6.0	3.5	3.0									
62.0	61.1mx 6.4	62mx 6.1	6.1	6.1	6.1	6.0	3.5	3.0	6.0	6.0	6.0	6.0	6.0	6.0	3.5	3.0									
64.0			5.7	5.7	5.7	5.7	3.5	3.0	63.7mx 5.6	5.5	5.5	5.5	5.5	5.5	5.5	3.5	3.0								
66.0			5.3	5.3	5.3	5.3	69mx 3.5	66mx 3.0		64.6mx 5.4	5.0	5.0	5.0	5.0	5.0	66mx 3.5	66mx 3.0								
68.0			66.6mx 5.1	68mx 4.9	68mx 4.9	68mx 4.9					4.6	4.6	4.6	4.6											
70.0											69.2mx 4.4	4.3	4.3	4.3	70mx 4.3										
72.0													70.6mx 4.2												

■ Aux. jib rated lifting loads (78ton counterweight, 16ton weight for body)

(Unit: metric ton)

Boom length (m)	60.0								63.0								66.0									
Jib length (m)	13.0		19.0		25.0		31.0		13.0		19.0		25.0		31.0		13.0		19.0		25.0		31.0			
Offset angle	10°	30°	10°	30°	10°	30°	10°	30°	10°	30°	10°	30°	10°	30°	10°	30°	10°	30°	10°	30°	10°	30°	10°	30°		
Working radius (m)	10°	30°	10°	30°	10°	30°	10°	30°	10°	30°	10°	30°	10°	30°	10°	30°	10°	30°	10°	30°	10°	30°	10°	30°		
16.0	16.7mx 13.5									17.2mx 13.5									17.7mx 13.5							
18.0	13.5		18.1mx 12.0							13.5		18.7mx 12.0							13.5		19.2mx 12.0					
20.0	13.5	20.6mx 13.0	12.0		20.8mx 8.0					13.5	21.1mx 13.0	12.0		21.3mx 8.0					13.5	21.6mx 13.0	12.0		21.8mx 8.0			
22.0	13.5	13.0	12.0	23.9mx 8.0	8.0			22.3mx 3.5		13.5	13.0	12.0		8.0		22.8mx 3.5			13.5	13.0	12.0		8.0		23.3mx 3.5	
24.0	13.5	13.0	12.0	8.0	8.0			3.5		13.5	13.0	12.0	24.4mx 8.0	8.0				13.5	13.0	12.0	25mx 8.0	8.0		3.5		
26.0	13.5	13.0	12.0	8.0	8.0			3.5		13.5	13.0	12.0	8.0	8.0		3.5		13.5	13.0	12.0	8.0	8.0		3.5		
28.0	13.5	13.0	12.0	8.0	8.0	28.3mx 6.0	3.5			13.5	13.0	12.0	8.0	8.0	28.8mx 6.0	3.5		13.5	13.0	12.0	8.0	8.0	29.3mx 6.0	3.5		
30.0	13.5	13.0	12.0	8.0	8.0	6.0	3.5	31.7mx 3.0		13.5	13.0	12.0	8.0	8.0	6.0	3.5		13.5	13.0	12.0	8.0	8.0	6.0	3.5		
32.0	13.5	13.0	12.0	8.0	8.0	6.0	3.5	3.0	13.5	13.0	12.0	8.0	8.0	8.0	6.0	3.5	32.2mx 3.0	13.5	13.0	12.0	8.0	8.0	6.0	3.5	32.7mx 3.0	
34.0	13.5	13.0	12.0	8.0	8.0	6.0	3.5	3.0	13.5	13.0	12.0	8.0	8.0	8.0	6.0	3.5	3.0	13.5	13.0	12.0	8.0	8.0	6.0	3.5	3.0	
36.0	13.5	13.0	12.0	8.0	8.0	6.0	3.5	3.0	13.5	13.0	12.0	8.0	8.0	8.0	6.0	3.5	3.0	13.5	13.0	12.0	8.0	8.0	6.0	3.5	3.0	
38.0	13.5	13.0	12.0	8.0	8.0	6.0	3.5	3.0	13.5	13.0	12.0	8.0	8.0	8.0	6.0	3.5	3.0	13.5	13.0	12.0	8.0	8.0	6.0	3.5	3.0	
40.0	13.2	13.0	12.0	8.0	8.0	6.0	3.5	3.0	13.0	13.0	12.0	8.0	8.0	8.0	6.0	3.5	3.0	12.8	12.8	12.0	8.0	8.0	6.0	3.5	3.0	
42.0	12.2	12.2	12.0	8.0	8.0	6.0	3.5	3.0	12.0	12.0	12.0	8.0	8.0	8.0	6.0	3.5	3.0	11.8	11.8	11.8	8.0	8.0	6.0	3.5	3.0	
44.0	11.3	11.3	11.3	8.0	8.0	6.0	3.5	3.0	11.1	11.1	11.1	8.0	8.0	8.0	6.0	3.5	3.0	10.9	10.9	10.9	8.0	8.0	6.0	3.5	3.0	
46.0	10.5	10.5	10.5	8.0	8.0	6.0	3.5	3.0	10.3	10.3	10.3	8.0	8.0	8.0	6.0	3.5	3.0	10.1	10.1	10.1	8.0	8.0	6.0	3.5	3.0	
48.0	9.8	9.8	9.8	8.0	8.0	6.0	3.5	3.0	9.6	9.6	9.6	8.0	8.0	8.0	6.0	3.5	3.0	9.4	9.4	9.4	8.0	8.0	6.0	3.5	3.0	
50.0	9.1	9.1	9.1	8.0	8.0	6.0	3.5	3.0	8.9	8.9	8.9	8.0	8.0	8.0	6.0	3.5	3.0	8.7	8.7	8.7	8.0	8.0	6.0	3.5	3.0	
52.0	8.4	8.4	8.4	8.0	8.0	6.0	3.5	3.0	8.3	8.3	8.3	8.0	8.0	8.0	6.0	3.5	3.0	8.1	8.1	8.1	8.0	8.0	6.0	3.5	3.0	
54.0	7.8	7.8	7.8	7.8	7.8	6.0	3.5	3.0	7.7	7.7	7.7	7.7	7.7	7.7	6.0	3.5	3.0	7.5	7.5	7.5	7.5	7.5	6.0	3.5	3.0	
56.0	7.3	7.3	7.3	7.3	7.3	6.0	3.5	3.0	7.2	7.2	7.2	7.2	7.2	7.2	6.0	3.5	3.0	7.0	7.0	7.0	7.0	7.0	6.0	3.5	3.0	
58.0	6.8	6.8	6.8	6.8	6.8	6.0	3.5	3.0	6.7	6.7	6.7	6.7	6.7	6.7	6.0	3.5	3.0	6.5	6.5	6.5	6.5	6.5	6.0	3.5	3.0	
60.0	6.3	6.3	6.3	6.3	6.3	6.0	3.5	3.0	6.1	6.1	6.1	6.1	6.1	6.1	6.0	3.5	3.0	5.9	5.9	5.9	5.9	5.9	5.9	5.9	3.5	3.0
62.0	5.8	5.8	5.8	5.8	5.8	5.8	3.5	3.0	5.6	5.6	5.6	5.6	5.6	5.6	5.6	3.5	3.0	5.4	5.4	5.4	5.4	5.4	5.4	5.4	3.5	3.0
64.0	5.3	5.3	5.3	5.3	5.3	5.3	3.5	3.0	5.1	5.1	5.1	5.1	5.1	5.1	5.1	3.5	3.0	4.9	4.9	4.9	4.9	4.9	4.9	4.9	3.5	3.0
66.0	4.8	4.8	4.8	4.8	4.8	4.8	3.5	3.0	4.6	4.6	4.6	4.6	4.6	4.6	4.6	3.5	3.0	4.4	4.4	4.4	4.4	4.4	4.4	4.4	3.5	3.0
68.0	66.3mx 4.8	67.2mx 4.6	4.4	4.4	4.4	4.4	3.5	3.0	4.2	4.2	4.2	4.2	4.2	4.2	4.2	3.5	3.0	4.0	4.0	4.0	4.0	4.0	4.0	4.0	3.5	3.0
70.0			4.1	4.1	4.1	4.1	3.5	3.0	68.9mx 4.0	69.8mx 3.9	3.8	3.8	3.8	3.8	3.8	3.5	3.0	3.6	3.6	3.6	3.6	3.6	3.6	3.6	3.5	3.0
72.0			71.8mx 3.8	3.7	3.7	3.7	3.5	3.0			3.5	3.5	3.5	3.5	3.5	3.5	3.0	71.5mx 3.4	3.3	3.3	3.3	3.3	3.3	3.3	3.3	3.0
74.0			73.2mx 3.5	3.3	3.3	3.3	3.3	3.0			3.1	3.1	3.1	3.1	3.1	3.1	3.0	72.4mx 3.2	2.9	2.9	2.9	2.9	2.9	2.9	2.9	2.9

Boom length (m)	69.0								72.0								
Jib length (m)	13.0		19.0		25.0		31.0		13.0		19.0		25.0		31.0		
Offset angle	10°	30°	10°	30°	10°	30°	10°	30°	10°	30°	10°	30°	10°	30°	10°	30°	
Working radius (m)	10°	30°	10°	30°	10°	30°	10°	30°	10°	30°	10°	30°	10°	30°	10°	30°	
18.0	18.2mx 13.5		19.7mx 12.0								18.7mx 13.5						
20.0	13.5		12.0								13.5		20.2mx 12.0				
22.0	13.5	22.1mx 13.0	12.0		22.4mx 8.0			23.9mx 3.5			13.5	22.6mx 13.0	12.0		22.9mx 8.0		
24.0	13.5	13.0	12.0	25.5mx 8.0	8.0			3.5		13.5	13.0	12.0	26mx 8.0	8.0		24.4mx 3.5	
26.0	13.5	13.0	12.0	8.0	8.0			3.5		13.5	13.0	12.0	8.0	8.0		3.5	
28.0	13.5	13.0	12.0	8.0	8.0	29.8mx 6.0	3.5			13.5	13.0	12.0	8.0	8.0		3.5	
30.0	13.5	13.0	12.0	8.0	8.0	6.0	3.5			13.5	13.0	12.0	8.0	8.0	30.3mx 6.0	3.5	
32.0	13.5	13.0	12.0	8.0	8.0	6.0	3.5	33.2mx 3.0		13.5	13.0	12.0	8.0	8.0	6.0	3.5	33.7mx 3.0
34.0	13.5	13.0	12.0	8.0	8.0	6.0	3.5	3.0	13.5	13.0	12.0	8.0	8.0	8.0	6.0	3.5	3.0
36.0	13.5	13.0	12.0	8.0	8.0	6.0	3.5	3.0	13.5	13.0	12.0	8.0	8.0	8.0	6.0	3.5	3.0
38.0	13.5	13.0	12.0	8.0	8.0	6.0	3.5	3.0	13.5	13.0	12.0	8.0	8.0	8.0	6.0	3.5	3.0
40.0	12.6	12.6	12.0	8.0	8.0	6.0	3.5	3.0	12.5	12.5	12.0	8.0	8.0	8.0	6.0	3.5	3.0
42.0	11.6	11.6	11.6	8.0	8.0	6.0	3.5	3.0	11.5	11.5	11.5	8.0	8.0	8.0	6.0	3.5	3.0
44.0	10.7	10.7	10.7	8.0	8.0	6.0	3.5	3.0	10.6	10.6	10.6	8.0	8.0	8.0	6.0	3.5	3.0
46.0	9.9	9.9	9.9	8.0	8.0	6.0	3.5	3.0	9.8	9.8	9.8	8.0	8.0	8.0	6.0	3.5	3.0
48.0	9.1	9.1	9.1	8.0	8.0	6.0	3.5	3.0	8.9	8.9	8.9	8.0	8.0	8.0	6.0	3.5	3.0
50.0	8.5	8.5	8.5	8.0	8.0	6.0	3.5	3.0	8.4	8.4	8.4	8.0	8.0	8.0	6.0	3.5	3.0
52.0	7.8	7.8	7.8	7.8	7.8	6.0	3.5	3.0	7.7	7.7	7.7	7.7	7.7	7.7	6.0	3.5	3.0
54.0	7.3	7.3	7.3	7.3	7.3	6.0	3.5	3.0	7.2	7.2	7.2	7.2	7.2	7.2	6.0	3.5	3.0
56.0	6.8	6.8	6.8	6.8	6.8	6.0	3.5	3.0	6.6	6.6	6.6	6.6	6.6	6.6	6.0	3.5	3.0
58.0	6.3	6.3	6.3	6.3	6.3	6.0	3.5	3.0	6.1	6.1	6.1	6.1	6.1	6.1	6.0	3.5	3.0
60.0	5.8	5.8	5.8	5.8	5.8	5.8	3.5	3.0	5.6	5.6	5.6	5.6	5.6	5.6	5.6	3.5	3.0
62.0	5.4	5.4	5.4	5.4	5.4	5.4	3.5	3.0	5.2	5.2	5.2	5.2	5.2	5.2	5.2	3.5	3.0
64.0	5.0	5.0	5.0	5.0	5.0	5.0	3.5	3.0	4.8	4.8	4.8	4.8	4.8	4.8	4.8	3.5	3.0
66.0	4.5	4.5	4.5	4.5	4.5	4.5	3.5	3.0	4.3	4.3	4.3	4.3	4.3	4.3	4.3	3.5	3.0
68.0	4.0	4.0	4.0	4.0	4.0	4.0	3.5	3.0	3.8	3.8	3.8	3.8	3.8	3.8	3.8	3.5	3.0
70.0	3.6	3.6	3.6	3.6	3.6	3.6	3.5	3.0	3.4	3.4	3.4	3.4	3.4	3.4	3.4	3.4	3.0
72.0	3.3	3.3	3.3	3.3	3.3	3.3	3.3	3.0	3.1	3.1	3.1	3.1	3.1	3.1	3.1	3.1	3.0
74.0	2.9	2.9	2.9	2.9	2.9	2.9	2.9	2.9	2.7	2.7	2.7	2.7	2.7	2.7	2.7	2.7	2.7

Notes

- Above rated loads are based on the machine being operated on firm level ground, within 78% of tipping load at any point of 360° around the machine with forward stability factor of over 1.15.
- Working radius is horizontal distance from center of rotation to a vertical line through the center of gravity of the load.
- When the main hook block

Luffing Jib Crane

CCH2000

Specifications

Max. Lifting capacity x working radius		at Post	50.0metric tons x 12.0m
		at Jib	25.0metric tons x 15.1m
Max. lift above ground level			
105.0m(60m post+51m jib)			
Rope speed	Main drum hoist/lowering	* 110~55/55~28m/min	
	Aux. drum hoist/lowering	* 110~55/55~28m/min	
	Post hoist/lowering	* 32~14m/min x 2	
	Jib hoist/lowering	* 66~30m/min	
Part line	at Post	Hook block capacity x Part line	50ton x 4
		Hook block capacity x Part line	25ton x 2
	at Jib	Hook block capacity x Part line	25ton x 2
		Hook block capacity x Part line	13.5ton x 1
Post hoist		18	
Jib hoist		8	
Counterweight		78ton	
Weight for body		16ton	
Total operating weight (with 60m post+50ton hook+51m jib+25ton hook+jib drum)		215ton	
Average ground bearing pressure		115kPa(1.17kg/cm ²)	

Note: The rope speed changes depending on the load.

Combination of Post and Jib

Jib length (m)	27	30	33	36	39	42	45	48	51
Post length (m)									
36	●	●	●	●	●	●	●	●	●
39	●	●	●	●	●	●	●	●	●
42	●	●	●	●	●	●	●	●	●
45	●	●	●	●	●	●	●	●	●
48	●	●	●	●	●	●	●	●	●
51	●	●	●	●	●	●	●	●	●
54	●	●	●	●	●	●	●	●	●
57	●	●	●	●	●	●	●	●	●
60	●	●	●	●	●	●	●	●	●

Note: ●:Possible combinations

Wire Rope

Place of use	Rope diameter (mm)	Guaranteed strength (t)	Rope type
Main drum	φ 28	70.2	P·S(19)+39 x P.7
Aux. drum	φ 28	70.2	P·S(19)+39 x P.7
Jib hoist	φ 26	57.8	IWRC6 x P·WS(31)
Post hoist	φ 22	36.3	IWRC6 x P·WS(31)
Jib suspension	φ 34	104.0	IWRC6 x P·WS(36)
Strut suspension	φ 34	104.0	IWRC6 x P·WS(36)
Post suspension	φ 34	104.0	IWRC6 x P·WS(36)

Luffing jib crane Post/jib composition

Post composition

* The following table shows standard combinations of post lengths when ordering the maximum post length specification (60m).

Post length (m)	36.0	39.0	42.0	45.0	48.0	51.0	54.0	57.0	60.0
Post composition									
7.5m inner	1	1	1	1	1	1	1	1	1
* 3.0m insert	1	1	1	1	1	1	1	1	1
* 3.0m insert	1	1	1	1	1	1	1	1	1
3.0m insert	—	—	1	—	—	1	—	1	2
6.0m insert	1	—	—	1	—	—	1	1	1
9.0m insert	1	2	2	2	3	3	3	3	3
1.5m outer	1	1	1	1	1	1	1	1	1

Notes:

(*1) 9.0m and 3.0m insert posts with the * mark include guardrails for the middle equalizer.

(*2) A pendant cable for extending the jib is also included with the 3.0m-9.0m insert posts.

Jib composition

The following table shows standard combinations of jib lengths when ordering the maximum jib length specification.

Jib length (m)	27	30	33	36	39	42	45	48	51
Jib composition									
9.0m inner	1	1	1	1	1	1	1	1	1
3.0m insert	—	1	—	—	1	—	1	—	1
6.0m insert	—	—	1	—	—	1	1	2	2
9.0m insert	1	1	1	2	2	2	2	2	2
9.0m outer	1	1	1	1	1	1	1	1	1

Optional Auxiliary Jib performance

Specifications

Max. lifting load x working radius (with 36m post+27m jib)	13.5metric tons x 27.6m (on jib hook)
Rope speed Load hoist/lowering	110~55/55~28m/min
Part line Optional aux. jib hoist x Part line	13.5ton x 1

Note: The rope speed changes depending on the load.

Jib combination

The auxiliary jib can be attached to all jibs from 27m to 51m.

Working range (No load condition)

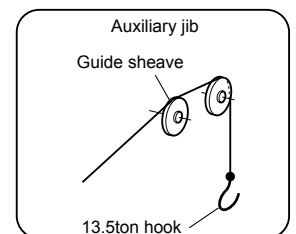
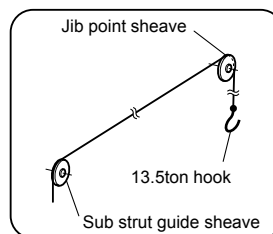
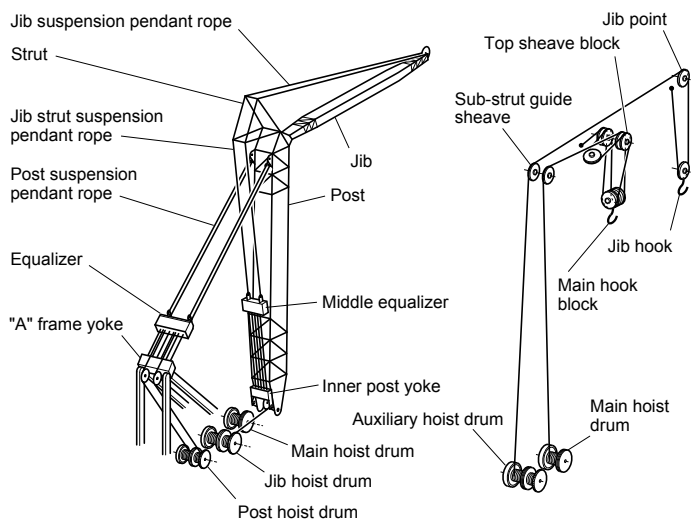
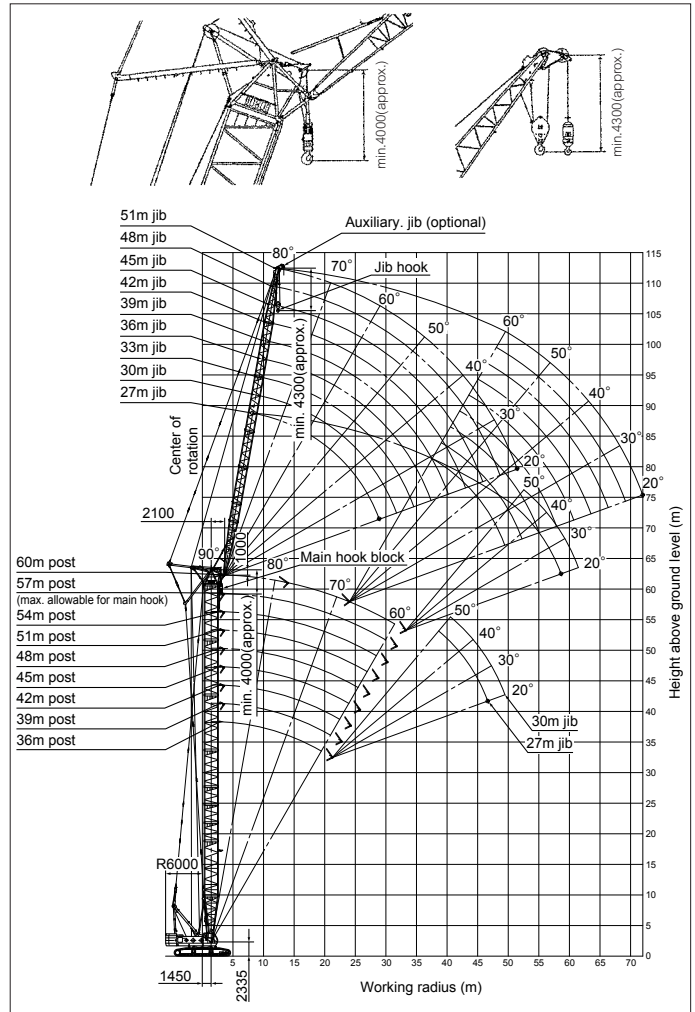

Luffing Jib Crane

CCH2000

■ Post rated lifting loads (78ton counterweight, 16ton weight for body)

(Unit: metric ton)

Post length (m)	36.0						39.0						33.0		
Jib length (m)	27.0			30.0			27.0			30.0			33.0		
Jib offset angle Working radius (m)	10~20°	20~40°	40°~	10~20°	20~40°	40°~	10~20°	20~40°	40°~	10~20°	20~40°	40°~	10~20°	20~40°	40°~
6.0	6.3m x 50.0	6.3m x 50.0	6.3m x 50.0	6.3m x 50.0	6.3m x 50.0	6.3m x 50.0	6.6m x 50.0	6.6m x 50.0	6.6m x 50.0	6.6m x 50.0	6.6m x 50.0	6.6m x 50.0	6.6m x 50.0	6.6m x 50.0	6.6m x 50.0
7.0	50.0	50.0	50.0	50.0	50.0	50.0	50.0	50.0	50.0	50.0	50.0	50.0	50.0	50.0	50.0
8.0	50.0	50.0	50.0	50.0	50.0	50.0	50.0	50.0	50.0	50.0	50.0	50.0	50.0	50.0	50.0
9.0	50.0	50.0	50.0	50.0	50.0	50.0	50.0	50.0	50.0	50.0	50.0	50.0	50.0	50.0	9.9m x 50.0
10.0	50.0	50.0	50.0	50.0	50.0	50.0	50.0	50.0	50.0	50.0	11.9m x 50.0	11.9m x 50.0	10.5m x 50.0	10.1m x 50.0	49.6
12.0	50.0	50.0	50.0	50.0	50.0	50.0	50.0	50.0	50.0	50.0	49.7	49.7	42.9	41.0	39.6
14.0	41.5	41.3	41.3	41.0	40.7	40.7	41.4	41.2	41.2	40.9	40.6	40.6	33.8	31.9	30.5
16.0	32.8	32.6	32.6	32.3	32.0	32.0	32.7	32.5	32.5	32.2	31.9	31.9	25.1	23.2	21.8
18.0	26.5	26.3	26.3	26.0	25.7	25.7	26.3	26.1	26.1	25.8	25.5	25.5	18.7	16.8	15.4
20.0	21.6	21.4	21.4	21.1	20.8	20.8	21.5	21.3	21.3	21.0	20.7	20.7	13.9	12.0	10.6
22.0	17.8	17.6	17.6	17.3	17.0	17.0	17.6	17.4	17.4	17.1	16.8	16.8	10.0	8.1	6.7
24.0	14.7	14.5	14.5	14.2	13.9	13.9	14.6	14.4	14.4	14.1	13.8	13.8	7.0	5.1	3.7
26.0	12.1	11.9	11.9	11.6	11.3	11.3	12.0	11.8	11.8	11.5	11.2	11.2	4.4	2.5	
28.0	10.0	9.8	9.8	9.5	9.2	9.2	9.9	9.7	9.7	9.4	9.1	9.1	2.3		
30.0	8.2	8.0	8.0	7.7	7.4	7.4	8.0	7.8	7.8	7.5	7.2	7.2			
32.0	6.6	6.4	6.4	6.1	5.8	5.8	6.5	6.3	6.3	6.0	5.7	5.7			
34.0	5.2	5.0	5.0	4.7	4.4	4.4	5.1	4.9	4.9	4.6	4.3	4.3			
36.0	34.3m x 5.1	34.3m x 4.9	34.3m x 4.9	34.3m x 4.6	34.3m x 4.3	34.3m x 4.3	3.9	3.7	3.7	3.4	3.1	3.1			
38.0							36.9m x 3.4	36.9m x 3.2	36.9m x 3.2	36.9m x 2.9	36.9m x 2.6	36.9m x 2.6			

Post length (m)	42.0									45.0					
Jib length (m)	27.0			30.0			33.0			36.0			27.0		
Jib offset angle Working radius (m)	10~20°	20~40°	40°~	10~20°	20~40°	40°~	10~20°	20~40°	40°~	10~20°	20~40°	40°~	10~20°	20~40°	40°~
6.0	6.8m x 50.0	6.8m x 50.0	6.8m x 50.0	6.8m x 50.0	6.8m x 50.0	6.8m x 50.0	6.8m x 50.0	6.8m x 50.0	6.8m x 50.0	6.8m x 50.0	6.8m x 50.0	6.8m x 50.0			
7.0	50.0	50.0	50.0	50.0	50.0	50.0	50.0	50.0	50.0	50.0	50.0	50.0	7.1m x 50.0	7.1m x 50.0	7.1m x 50.0
8.0	50.0	50.0	50.0	50.0	50.0	50.0	50.0	50.0	50.0	50.0	50.0	50.0	50.0	50.0	50.0
9.0	50.0	50.0	50.0	50.0	50.0	50.0	50.0	50.0	9.9m x 50.0	50.0	50.0	9.7m x 50.0	50.0	50.0	50.0
10.0	50.0	50.0	50.0	11.9m x 50.0	11.9m x 50.0	11.9m x 50.0	10.5m x 50.0	10.1m x 50.0	49.5	10.4m x 50.0	50.0	48.4	50.0	50.0	50.0
12.0	50.0	50.0	50.0	49.9	49.6	49.6	42.8	40.9	39.5	42.1	40.0	38.4	50.0	50.0	50.0
14.0	41.3	41.1	41.1	40.8	40.5	40.5	33.7	31.8	30.4	33.0	30.9	29.3	41.1	40.9	40.9
16.0	32.6	32.4	32.4	32.1	31.8	31.8	25.0	23.1	21.7	24.3	22.2	20.6	32.4	32.2	32.2
18.0	26.2	26.0	26.0	25.7	25.4	25.4	18.6	16.7	15.3	17.9	15.8	14.2	26.0	25.8	25.8
20.0	21.3	21.1	21.1	20.8	20.5	20.5	13.7	11.8	10.4	13.0	10.9	9.3	21.2	21.0	21.0
22.0	17.5	17.3	17.3	17.0	16.7	16.7	9.9	8.0	6.6	9.2	7.1	5.5	17.3	17.1	17.1
24.0	14.4	14.2	14.2	13.9	13.6	13.6	6.8	4.9	3.5	6.1	4.0	2.4	14.3	14.1	14.1
26.0	11.8	11.6	11.6	11.3	11.0	11.0	4.2	2.3		3.5			11.7	11.5	11.5
28.0	9.7	9.5	9.5	9.2	8.9	8.9	2.1						9.5	9.3	9.3
30.0	7.9	7.7	7.7	7.4	7.1	7.1							7.7	7.5	7.5
32.0	6.3	6.1	6.1	5.8	5.5	5.5							6.1	5.9	5.9
34.0	4.9	4.7	4.7	4.4	4.1	4.1							4.8	4.6	4.6
36.0	3.7	3.5	3.5	3.2	2.9	2.9							3.6	3.4	3.4
38.0	2.7	2.5	2.5	2.2									2.5	2.3	2.3

Post length (m)	45.0									48.0					
Jib length (m)	30.0			33.0			36.0			39.0			27.0		
Jib offset angle Working radius (m)	10~20°	20~40°	40°~	10~20°	20~40°	40°~	10~20°	20~40°	40°~	10~20°	20~40°	40°~	10~20°	20~40°	40°~
6.0															
7.0	7.1m x 50.0	7.1m x 50.0	7.1m x 50.0	7.1m x 50.0	7.1m x 50.0	7.1m x 50.0	7.1m x 50.0	7.1m x 50.0	7.1m x 50.0	7.1m x 50.0	7.1m x 50.0	7.1m x 50.0	7.3m x 50.0	7.3m x 50.0	7.3m x 50.0
8.0	50.0	50.0	50.0	50.0	50.0	50.0	50.0	50.0	50.0	50.0	50.0	50.0	50.0	50.0	50.0
9.0	50.0	50.0	50.0	50.0	50.0	9.8m x 50.0	50.0	9.9m x 50.0	9.6m x 50.0	50.0	9.7m x 50.0	9.2m x 50.0	50.0	50.0	50.0
10.0	11.9m x 50.0	11.9m x 50.0	11.9m x 50.0	10.5m x 50.0	10.1m x 50.0	49.3	10.3m x 50.0	49.8	48.2	10.2m x 50.0	48.6	46.4	50.0	50.0	50.0
12.0	49.7	49.4	49.4	42.6	40.7	39.3	41.9	39.8	38.2	41.1	38.6	36.4	50.0	50.0	50.0
14.0	40.6	40.3	40.3	33.5	31.6	30.2	32.8	30.7	29.1	32.0	29.5	27.3	41.0	40.8	40.8
16.0	31.9	31.6	31.6	24.8	22.9	21.5	24.1	22.0	20.4	23.3	20.8	18.6	32.3	32.1	32.1
18.0	25.5	25.2	25.2	18.4	16.5	15.1	17.7	15.6	14.0	16.9	14.4	12.2	25.9	25.7	25.7
20.0	20.7	20.4	20.4	13.6	11.7	10.3	12.9	10.8	9.2	12.1	9.6	7.4	21.0	20.8	20.8
22.0	16.8	16.5	16.5	9.7	7.8	6.4	9.0	6.9	5.3	8.2	5.7	3.5	17.2	17.0	17.0
24.0	13.8	13.5	13.5	6.7	4.8	3.4	6.0	3.9	2.3	5.2	2.7		14.1	13.9	13.9
26.0	11.2	10.9	10.9	4.1	2.2		3.4			2.6			11.5	11.3	11.3
28.0	9.0	8.7	8.7										9.4	9.2	9.2
30.0	7.2	6.9	6.9										7.6	7.4	7.4
32.0	5.6	5.3	5.3										6.0	5.8	5.8
34.0	4.3	4.0	4.0										4.6	4.4	4.4
36.0	3.1	2.8	2.8										3.4	3.2	3.2
38.0	2.0												2.3	2.1	2.1

Luffing Jib Crane

GCH2000

■ Post rated lifting loads (78ton counterweight, 16ton weight for body)

(Unit:metric ton)

Post length (m)	30.0						48.0			39.0			42.0		
Jib length (m)	30.0			33.0			36.0			39.0			42.0		
Jib offset angle Working radius (m)	10~20°	20~40°	40°~	10~20°	20~40°	40°~	10~20°	20~40°	40°~	10~20°	20~40°	40°~	10~20°	20~40°	40°~
6.0															
7.0	7.3m x 50.0	7.3m x 50.0	7.3m x 50.0	7.3m x 50.0	7.3m x 50.0	7.3m x 50.0	7.3m x 50.0	7.3m x 50.0	7.3m x 50.0	7.3m x 50.0	7.3m x 50.0	7.3m x 50.0	7.3m x 50.0	7.3m x 50.0	7.3m x 50.0
8.0	50.0	50.0	50.0	50.0	50.0	50.0	50.0	50.0	50.0	50.0	50.0	50.0	50.0	50.0	50.0
9.0	50.0	50.0	50.0	50.0	50.0	9.7m x 50.0	50.0	9.9m x 50.0	9.5m x 50.0	50.0	9.6m x 50.0	9.2m x 50.0	50.0	9.4m x 50.0	50.0
10.0	11.9m x 50.0	11.8m x 50.0	11.8m x 50.0	10.4m x 50.0	50.0	49.2	10.3m x 50.0	49.7	48.1	10.1m x 50.0	48.5	46.3	50.0	47.4	44.7
12.0	49.6	49.3	49.3	42.5	40.6	39.2	41.8	39.7	38.1	41.0	38.5	36.3	40.2	37.4	34.7
14.0	40.5	40.2	40.2	33.4	31.5	30.1	32.7	30.6	29.0	31.9	29.4	27.2	31.1	28.3	25.6
16.0	31.8	31.5	31.5	24.7	22.8	21.4	24.0	21.9	20.3	23.2	20.7	18.5	22.4	19.6	16.9
18.0	25.4	25.1	25.1	18.3	16.4	15.0	17.6	15.5	13.9	16.8	14.3	12.1	16.0	13.2	10.5
20.0	20.5	20.2	20.2	13.4	11.5	10.1	12.7	10.6	9.0	11.9	9.4	7.2	11.1	8.3	5.6
22.0	16.7	16.4	16.4	9.6	7.7	6.3	8.9	6.8	5.2	8.1	5.6	3.4	7.3	4.5	
24.0	13.6	13.3	13.3	6.5	4.6	3.2	5.8	3.7	2.1	5.0	2.5		4.2		
26.0	11.0	10.7	10.7	3.9	2.0		3.2			2.4					
28.0	8.9	8.6	8.6												
30.0	7.1	6.8	6.8												
32.0	5.5	5.2	5.2												
34.0	4.1	3.8	3.8												
36.0	2.9	2.6	2.6												
38.0															

Post length (m)	27.0						30.0			51.0			33.0			36.0			39.0			
Jib length (m)	27.0			30.0			33.0			36.0			39.0			42.0			45.0			
Jib offset angle Working radius (m)	10~20°	20~40°	40°~	10~20°	20~40°	40°~	10~20°	20~40°	40°~	10~20°	20~40°	40°~	10~20°	20~40°	40°~	10~20°	20~40°	40°~	10~20°	20~40°	40°~	
6.0																						
7.0	7.6m x 50.0	7.6m x 50.0	7.6m x 50.0	7.6m x 50.0	7.6m x 50.0	7.6m x 50.0	7.6m x 50.0	7.6m x 50.0	7.6m x 50.0	7.6m x 50.0	7.6m x 50.0	7.6m x 50.0	7.6m x 50.0	7.6m x 50.0	7.6m x 50.0	7.6m x 50.0	7.6m x 50.0	7.6m x 50.0	7.6m x 50.0	7.6m x 50.0	7.6m x 50.0	7.6m x 50.0
8.0	50.0	50.0	50.0	50.0	50.0	50.0	50.0	50.0	50.0	50.0	50.0	50.0	50.0	50.0	50.0	50.0	50.0	50.0	50.0	50.0	50.0	50.0
9.0	50.0	50.0	50.0	50.0	50.0	50.0	50.0	50.0	50.0	9.6m x 50.0	50.0	9.8m x 50.0	9.4m x 50.0	50.0	9.5m x 50.0	50.0						
10.0	50.0	50.0	50.0	11.8m x 50.0	11.7m x 50.0	11.7m x 50.0	10.3m x 50.0	50.0	49.1	10.2m x 50.0	49.6	48.0	50.0	48.4	46.2							
12.0	50.0	50.0	50.0	49.5	49.2	49.2	42.4	40.5	39.1	41.7	39.6	38.0	40.9	38.4	36.2							
14.0	40.9	40.7	40.7	40.4	40.1	40.1	33.3	31.4	30.0	32.6	30.5	28.9	31.8	29.3	27.1							
16.0	32.1	31.9	31.9	31.6	31.3	31.3	24.5	22.6	21.2	23.8	21.7	20.1	23.0	20.5	18.3							
18.0	25.8	25.6	25.6	25.3	25.0	25.0	18.2	16.3	14.9	17.5	15.4	13.8	16.7	14.2	12.0							
20.0	20.9	20.7	20.7	20.4	20.1	20.1	13.3	11.4	10.0	12.6	10.5	8.9	11.8	9.3	7.1							
22.0	17.1	16.9	16.9	16.6	16.3	16.3	9.5	7.6	6.2	8.8	6.7	5.1	8.0	5.5	3.3							
24.0	14.0	13.8	13.8	13.5	13.2	13.2	6.4	4.5	3.1	5.7	3.6	2.0	4.9	2.4								
26.0	11.4	11.2	11.2	10.9	10.6	10.6	3.8			3.1			2.3									
28.0	9.2	9.0	9.0	8.7	8.4	8.4																
30.0	7.4	7.2	7.2	6.9	6.6	6.6																
32.0	5.8	5.6	5.6	5.3	5.0	5.0																
34.0	4.5	4.3	4.3	4.0	3.7	3.7																
36.0	3.3	3.1	3.1	2.8	2.5	2.5																
38.0	2.2	2.0	2.0																			

Post length (m)	27.0						30.0			51.0			33.0			36.0			39.0			
Jib length (m)	27.0			30.0			33.0			36.0			39.0			42.0			45.0			
Jib offset angle Working radius (m)	10~20°	20~40°	40°~	10~20°	20~40°	40°~	10~20°	20~40°	40°~	10~20°	20~40°	40°~	10~20°	20~40°	40°~	10~20°	20~40°	40°~	10~20°	20~40°	40°~	
6.0																						
7.0	7.6m x 50.0	7.6m x 50.0	7.6m x 50.0	7.6m x 50.0	7.6m x 50.0	7.6m x 50.0	7.9m x 50.0	7.9m x 50.0	7.9m x 50.0	7.9m x 50.0	7.9m x 50.0	7.9m x 50.0	7.9m x 50.0	7.9m x 50.0	7.9m x 50.0	7.9m x 50.0	7.9m x 50.0	7.9m x 50.0	7.9m x 50.0	7.9m x 50.0	7.9m x 50.0	7.9m x 50.0
8.0	50.0	50.0	6.9m x 50.0	50.0	50.0	8.5m x 50.0	50.0	50.0	50.0	50.0	50.0	50.0	50.0	50.0	50.0	50.0	50.0	50.0	50.0	50.0	50.0	50.0
9.0	50.0	9.4m x 50.0	49.6	9.8m x 50.0	50.0	47.9	50.0	50.0	50.0	50.0	50.0	50.0	50.0	50.0	50.0	50.0	50.0	50.0	50.0	50.0	9.4m x 50.0	50.0
10.0	50.0	47.3	44.6	49.4	45.9	42.9	11.9m x 50.0	11.9m x 50.0	11.9m x 50.0	11.6m x 50.0	11.5m x 50.0	11.5m x 50.0	10.1m x 50.0	50.0	48.9							
12.0	40.1	37.3	34.6	39.4	35.9	32.9	49.8	49.6	49.6	49.3	49.0	49.0	42.2	40.3	38.9							
14.0	31.0	28.2	25.5	30.3	26.8	23.8	40.7	40.5	40.5	40.2	39.9	39.9	33.1	31.2	29.8							
16.0	22.2	19.4	16.7	21.5	18.0	15.0	32.0	31.8	31.8	31.5	31.2	31.2	24.4	22.5	21.1							
18.0	15.9	13.1	10.4	15.2	11.7	8.7	25.6	25.4	25.4	25.1	24.8	24.8	18.0	16.1	14.7							
20.0	11.0	8.2	5.5	10.3	6.8	3.8	20.8	20.6	20.6	20.3	20.0	20.0	13.2	11.3	9.9							
22.0	7.2	4.4		6.5	3.0		16.9	16.7	16.7	16.4	16.1	16.1	9.3	7.4	6.0							
24.0	4.1			3.4			13.8	13.6	13.6	13.3	13.0	13.0	6.2	4.3	2.9							
26.0							11.2	11.0	11.0	10.7	10.4	10.4	3.6									
28.0							9.1	8.9	8.9	8.6	8.3	8.3										
30.0							7.3	7.1	7.1	6.8	6.5	6.5										
32.0							5.7	5.5	5.5	5.2	4.9	4.9										
34.0							4.3	4.1	4.1	3.8	3.5	3.5										
36.0							3.1	2.9	2.9	2.6	2.3	2.3										
38.0							2.0															

Luffing Jib Crane

CCH2000

Jib rated lifting loads (78ton counterweight, 16ton weight for body)

(Unit:metric ton)

Post length (m)	36.0								39.0											
Jib length (m)	27.0				30.0				27.0				30.0				33.0			
Post angle Working radius (m)	90°	80°	70°	60°	90°	80°	70°	60°	90°	80°	70°	60°	90°	80°	70°	60°	90°	80°	70°	
8.0	8.3m x 25.0				8.8m x 25.0				8.3m x 25.0				8.8m x 25.0							
9.0	25.0				25.0				25.0				25.0				9.3m x 25.0			
10.0	25.0				25.0				25.0				25.0				25.0			
12.0	25.0				25.0				25.0				25.0				25.0			
14.0	15.1m x 25.0				14.3m x 25.0				15.1m x 25.0				14.3m x 25.0				25.0			
16.0	24.6				23.6				24.6				23.6				23.2			
18.0	23.7	19.0m x 23.3			22.0				23.7	19.5m x 23.0			22.0				21.6			
20.0	22.9	22.9			21.0	21.0			22.9	22.9			21.0	20.5m x 20.8			20.3	21.5m x 19.6		
22.0	21.5	21.5			20.0	20.0			21.5	21.5			20.0	20.0			19.3	19.3		
24.0	19.2	19.2			19.2	19.2			19.2	19.2			19.2	19.2			18.4	18.4		
26.0	16.0	16.0			17.9	17.9			16.0	16.0			17.9	17.9			18.0	18.0		
28.0	13.6	13.6	29.1m x 12.8		15.7	15.7			13.6	13.6			15.7	15.7			16.2	16.2		
30.0	28.4m x 13.4	12.1	12.1		12.6	12.6	30.6m x 12.2		28.4m x 13.4	12.1	30.1m x 12.1		12.6	12.6	31.6m x 11.5		14.1	14.1		
32.0		11.2	11.2		31.3m x 11.7	11.1	11.1			11.2	11.2		31.3m x 11.7	11.1	11.1		12.1	12.1	33.1m x 11.2	
34.0		10.7	10.7			10.5	10.5			10.7	10.7			10.5	10.5		10.5	10.5	10.5	
36.0		34.7m x 10.5	10.1			9.9	9.9			35.2m x 10.3	10.1			9.9	9.9		34.1m x 10.5	9.4	9.4	
38.0			9.5	38.4m x 9.3		37.5m x 9.5	9.4				9.5	39.9m x 8.8		9.4	9.4			9.0	9.0	
40.0			8.7	8.7		8.5	40.4m x 8.4				8.7	8.7			8.5	41.9m x 8.0		8.5	8.5	
42.0			40.6m x 8.6	8.2		8.0	8.0				41.6m x 8.3	8.2		8.0	8.0		40.8m x 8.3	8.0	8.0	
44.0				7.6		43.4m x 7.6	7.5				7.6	7.6			7.5	7.5		7.5	7.5	
46.0				7.2			7.0				7.2	7.2			44.4m x 7.4	7.0		7.0	7.0	
48.0				46.1m x 7.2			6.6				47.6m x 6.8					6.6		47.3m x 6.7		
50.0							49.0m x 6.4									6.2				
52.0																50.5m x 6.1				

Post length (m)	42.0												45.0							
Jib length (m)	27.0				30.0				33.0				36.0				27.0			
Post angle Working radius (m)	90°	80°	70°	60°	90°	80°	70°	60°	90°	80°	70°	90°	80°	70°	90°	80°	70°	60°		
8.0	8.3m x 25.0				8.8m x 25.0										8.3m x 25.0					
9.0	25.0				25.0				9.3m x 25.0			9.8m x 23.5			25.0					
10.0	25.0				25.0				25.0			23.5			25.0					
12.0	25.0				25.0				25.0			23.5			25.0					
14.0	15.1m x 25.0				14.3m x 25.0				25.0			14.8m x 23.5			15.1m x 25.0					
16.0	24.6				23.6				23.2			22.4			24.6					
18.0	23.7				22.0				21.6			20.6			23.7					
20.0	22.9	22.9			21.0	21.0m x 20.5			20.3			19.4			22.9	20.5m x 22.5				
22.0	21.5	21.5			20.0	20.0			19.3	22.1m x 19.3		18.4	23.1m x 18.0		21.5	21.5				
24.0	19.2	19.2			19.2	19.2			18.4	18.4		17.6	17.6		19.2	19.2				
26.0	16.0	16.0			17.9	17.9			18.0	18.0		16.8	16.8		16.0	16.0				
28.0	13.6	13.6			15.7	15.7			16.2	16.2		16.1	16.1		13.6	13.6				
30.0	28.4m x 13.4	12.1	31.2m x 11.6		12.6	12.6			14.1	14.1		14.4	14.4		28.4m x 13.4	12.1				
32.0		11.2	11.2		31.3m x 11.7	11.1	32.7m x 10.9		12.1	12.1		13.1	13.1		11.2	32.2m x 11.2				
34.0		10.7	10.7			10.5	10.5		10.5	10.5	34.2m x 10.5	11.5	11.5	35.7m x 10.1		10.7	10.7			
36.0		35.7m x 10.2	10.1			9.9	9.9		34.1m x 10.5	9.4	9.4	9.9	9.9	9.9		10.1	10.1			
38.0			9.5			9.4	9.4			9.0	9.0	36.9m x 9.3	8.7	8.7		36.2m x 10.0	9.5			
40.0			8.7	41.4m x 8.3		38.5m x 9.1	8.5			8.5	8.5		8.3	8.3			8.7			
42.0			8.2	8.2		8.0	43.4m x 7.7			41.3m x 8.2	8.0		7.9	7.9			8.2	42.9m x 7.9		
44.0			42.7m x 8.0	7.6		7.5	7.5			7.5	7.5		7.4	7.4			43.7m x 7.7	7.6		
46.0				7.2			45.5m x 7.1	7.0			7.0		44.1m x 7.4	7.0				7.2		
48.0				6.7			6.6				6.6			6.5				6.7		
50.0				49.1m x 6.4			6.2				48.3m x 6.5			6.1				6.2		
52.0							5.8							51.1m x 5.9				50.6m x 6.1		

Notes

- Above rated loads are based on the machine being operated on firm level ground, within 78% of tipping load at any point of 360° around the machine with forward stability factor of over 1.15.
- The weight of hook blocks must be considered to be a part of the loads.
50ton hook block...1.00ton 30ton hook block...1.00ton
25ton hook block...1.00ton 13.5ton hook block...0.60ton
- Depending on the number of part lines, rated load is limited as follows:
1part line...up to 13.5ton
2part line...up to 25.0ton
- The angle of the center line of the post and the center line of the jib (offset angle) must not be less than 10°.
- The angle of the center line of the jib to level ground (tower jib angle) must not be less than 20° under loaded conditions.
- The auxiliary jib can be attached to all jibs(27m-51m).
- When attaching the auxiliary jib, the jib rated loads must be reduced by 0.5t from the figure shown in the above table.
- The rated loads of the auxiliary jib is equivalent to that of jib attached but to be reduced by 0.5ton. The maximum rated load of the auxiliary jib is 13.5ton.

Luffing Jib Crane

CCH2000

■ Jib rated lifting loads (78ton counterweight, 16ton weight for body)

(Unit: metric ton)

Post length (m)	45.0															48.0			
Jib length (m)	30.0				33.0			36.0			39.0			27.0					
Post angle Working radius (m)	90°	80°	70°	60°	90°	80°	70°	90°	80°	70°	90°	80°	70°	90°	80°	70°	60°		
8.0	8.8m x 25.0																	8.3m x 25.0	
9.0	25.0				9.3m x 25.0			9.8m x 23.5										25.0	
10.0	25.0				25.0			23.5						10.3m x 21.5				25.0	
12.0	25.0				25.0			23.5						21.5				25.0	
14.0	14.3m x 25.0				25.0			14.8m x 23.5						15.1m x 21.5				15.1m x 25.0	
16.0	23.6				23.2			22.4						21.0				24.6	
18.0	22.0				21.6			20.6						19.8				23.7	
20.0	21.0	21.6m x 20.2			20.3			19.4						18.6				22.9	
22.0	20.0	20.0			19.3	22.6m x 19.0		18.4	23.6m x 17.8					17.6				21.5	
24.0	19.2	19.2			18.4	18.4		17.6	17.6					16.8	24.6m x 16.4			19.2	
26.0	17.9	17.9			18.0	18.0		16.8	16.8					15.7	15.7			16.0	
28.0	15.7	15.7			16.2	16.2		16.1	16.1					15.0	15.0			13.6	
30.0	12.6	12.6			14.1	14.1		14.4	14.4					14.5	14.5			12.1	
32.0	31.3m x 11.7	11.1	33.7m x 10.6		12.1	12.1		13.1	13.1					13.1	13.1			11.2	
34.0		10.5	10.5		10.5	10.5	35.2m x 9.9	11.5	11.5					11.7	11.7			10.7	
36.0		9.9	9.9		34.1m x 10.5	9.4	9.4	9.9	9.9	36.7m x 9.4				10.4	10.4			10.1	
38.0		9.4	9.4			9.0	9.0	36.9m x 9.3	8.7	8.7				9.2	9.2	38.2m x 9.1		9.5	
40.0		39.0m x 9.0	8.5			8.5	8.5		8.3	8.3	39.7m x 8.3			8.2	8.2			8.7	
42.0			8.0			41.8m x 8.1	8.0		7.9	7.9				7.7	7.7			8.2	
44.0			7.5	44.9m x 7.3			7.5		7.4	7.4				7.3	7.3			7.6	
46.0			7.0	7.0			7.0		44.7m x 7.3	7.0				6.8	6.8			7.2	
48.0			46.5m x 6.9	6.6			6.6							47.5m x 6.5	6.4			6.7	
50.0				6.2			49.3m x 6.3							6.1		6.1		6.2	
52.0				5.8										5.7		5.7		5.8	
54.0				53.5m x 5.6										52.1m x 5.7		5.4		5.8	
56.0															55.0m x 5.2			5.8	

Post length (m)	48.0																
Jib length (m)	30.0				33.0			36.0			39.0			42.0			
Post angle Working radius (m)	90°	80°	70°	60°	90°	80°	70°	90°	80°	70°	90°	80°	70°	90°	80°	70°	
8.0	8.8m x 25.0																
9.0	25.0				9.3m x 25.0			9.8m x 23.5									
10.0	25.0				25.0			23.5						10.3m x 21.5			10.9m x 19.0
12.0	25.0				25.0			23.5						21.5			19.0
14.0	14.3m x 25.0				25.0			14.8m x 23.5						15.1m x 21.5			19.0
16.0	23.6				23.2			22.4						21.0			16.7m x 19.0
18.0	22.0				21.6			20.6						19.8			18.8
20.0	21.0				20.3			19.4						18.6			18.4
22.0	20.0	22.1m x 20.0			19.3	23.1m x 18.8		18.4						17.6			17.4
24.0	19.2	19.2			18.4	18.4		17.6	24.1m x 17.6					16.8	25.1m x 16.2		16.5
26.0	17.9	17.9			18.0	18.0		16.8	16.8					15.7	15.7		15.5
28.0	15.7	15.7			16.2	16.2		16.1	16.1					15.0	15.0		14.7
30.0	12.6	12.6			14.1	14.1		14.4	14.4					14.5	14.5		14.1
32.0	31.3m x 11.7	11.1			12.1	12.1		13.1	13.1					13.1	13.1		13.1
34.0		10.5	34.7m x 10.3		10.5	10.5		11.5	11.5					11.7	11.7		11.8
36.0		9.9	9.9		34.1m x 10.5	9.4	36.2m x 9.4	9.9	9.9	37.7m x 8.8				10.4	10.4		10.7
38.0		9.4	9.4			9.0	9.0	36.9m x 9.3	8.7	8.7				9.2	9.2	39.2m x 8.6	9.6
40.0		39.5m x 8.7	8.5			8.5	8.5		8.3	8.3	39.7m x 8.3			8.2	8.2		40.7m x 8.2
42.0			8.0			8.0	8.0		7.9	7.9				7.7	7.7		7.6
44.0			7.5			42.4m x 7.9	7.5		7.4	7.4				7.3	7.3	42.5m x 7.4	7.0
46.0			7.0	46.4m x 6.9			7.0		45.2m x 7.2	7.0				6.8	6.8		6.7
48.0			47.5m x 6.7	6.6			6.6							6.4	6.4		6.3
50.0				6.2			6.2							6.1		6.1	6.0
52.0				5.8			50.3m x 6.1							5.7		5.7	50.8m x 5.9
54.0				5.5										53.2m x 5.5		5.4	5.4
56.0				55.0m x 5.3												5.0	5.0
58.0																	4.8
60.0																	58.8m x 4.7

Luffing Jib Crane

GCH2000

■ Jib rated lifting loads (78ton counterweight, 16ton weight for body)

(Unit: metric ton)

Post length (m)	51.0																			
Jib length (m)	27.0				30.0				33.0				36.0				39.0			
Post angle	Working radius (m)																			
Working radius (m)	90°	80°	70°	60°	90°	80°	70°	60°	90°	80°	70°	60°	90°	80°	70°	60°	90°	80°	70°	60°
8.0	8.3m x 25.0				8.8m x 25.0															
9.0	25.0				25.0							9.3m x 25.0				9.8m x 23.5				
10.0	25.0				25.0							25.0				23.5			10.3m x 21.5	
12.0	25.0				25.0							25.0				23.5			21.5	
14.0	15.1m x 25.0				14.3m x 25.0							25.0				14.8m x 23.5			15.1m x 21.5	
16.0	24.6				23.6							23.2				22.4			21.0	
18.0	23.7				22.0							21.6				20.6			19.8	
20.0	22.9	21.6m x 21.7			21.0							20.3				19.4			18.6	
22.0	21.5	21.5			20.0	22.6m x 19.8						19.3	23.6m x 18.6			18.4			17.6	
24.0	19.2	19.2			19.2	19.2						18.4	18.4			17.6	24.6m x 17.4		16.8	25.7m x 15.9
26.0	16.0	16.0			17.9	17.9						18.0	18.0			16.8	16.8		15.7	15.7
28.0	13.6	13.6			15.7	15.7						16.2	16.2			16.1	16.1		15.0	15.0
30.0	28.4m x 13.4	12.1			12.6	12.6						14.1	14.1			14.4	14.4		14.5	14.5
32.0		11.2			31.3m x 11.7	11.1						12.1	12.1			13.1	13.1		13.1	13.1
34.0		10.7	34.2m x 10.6			10.5	35.7m x 10.0					10.5	10.5			11.5	11.5		11.7	11.7
36.0		10.1	10.1			9.9	9.9					34.1m x 10.5	9.4	37.2m x 9.2		9.9	9.9		10.4	10.4
38.0		37.2m x 9.7	9.5			9.4	9.4					9.0	9.0			36.9m x 9.5	8.7	38.7m x 8.5	9.2	9.2
40.0			8.7			8.5	8.5					8.5	8.5			8.3	8.3	39.7m x 8.3	8.2	40.2m x 8.1
42.0			8.2			40.1m x 8.5	8.0					8.0	8.0			7.9	7.9		7.7	7.7
44.0			7.6	45.9m x 7.2			7.5					42.9m x 7.8	7.5			7.4	7.4		7.3	7.3
46.0			45.7m x 7.2	7.2			7.0	47.9m x 6.6				7.0	7.0			45.7m x 7.1	7.0		6.8	6.8
48.0				6.7			6.6	6.6				6.6	6.6				6.5		6.4	6.4
50.0				6.2			48.6m x 6.5	6.2				6.2	6.2				6.1	48.5m x 6.3	6.1	6.1
52.0				5.8				5.8				51.4m x 5.9					5.7		5.7	5.7
54.0				53.6m x 5.5				5.5									5.4		5.4	5.4
56.0								5.1									54.2m x 5.3		5.0	5.0
58.0								56.5m x 5.1											57.0m x 4.9	5.0

Post length (m)	51.0												54.0						
Jib length (m)	42.0			45.0			27.0			30.0			33.0						
Post angle	Working radius (m)																		
Working radius (m)	90°	80°	70°	90°	80°	70°	90°	80°	70°	60°	90°	80°	70°	60°	90°	80°	70°		
8.0											8.3m x 25.0				8.8m x 25.0				
9.0											25.0				25.0			9.3m x 25.0	
10.0	10.9m x 19.0										25.0				25.0			25.0	
12.0	19.0										25.0				25.0			25.0	
14.0	19.0										15.1m x 25.0				14.3m x 25.0			25.0	
16.0	16.7m x 19.0										24.6				23.6			23.2	
18.0	18.8										23.7				22.0			21.6	
20.0	18.4										22.9				21.0			20.3	
22.0	17.4										21.5	22.1m x 21.3			20.0	23.1m x 19.5		19.3	
24.0	16.5										19.2	19.2			19.2	19.2		18.4	24.1m x 18.4
26.0	15.5	26.7m x 15.2									16.0	16.0			17.9	17.9		18.0	18.0
28.0	14.7	14.7									13.6	13.6			15.7	15.7		16.2	16.2
30.0	14.1	14.1									28.4m x 13.4	12.1			12.6	12.6		14.1	14.1
32.0	13.1	13.1									11.2				31.3m x 11.7	11.1		12.1	12.1
34.0	11.8	11.8									10.7	35.3m x 10.3			10.5			10.5	10.5
36.0	10.7	10.7									10.1	10.1			9.9	36.8m x 9.7		34.1m x 10.5	9.4
38.0	9.6	9.6									37.8m x 9.5	9.5			9.4	9.4		9.0	38.3m x 8.9
40.0	8.5	8.5	41.7m x 7.7								8.7	8.7			8.5	8.5		8.5	8.5
42.0	7.6	7.6	7.6	8.0							43.2m x 7.4				40.6m x 8.4	8.0		8.0	8.0
44.0	42.5m x 7.4	7.0	7.0	7.0	7.0						7.6				7.5			43.4m x 7.7	7.5
46.0		6.7	6.7	45.3m x 6.7	6.5	6.5					7.2	47.4m x 6.8			7.0			7.0	7.0
48.0		6.3	6.3		6.2	6.2					46.8m x 7.0	6.7			6.6	49.4m x 6.3		6.6	6.6
50.0		6.0	6.0		5.9	5.9					6.2	6.2			49.6m x 6.3	6.2		6.2	6.2
52.0		51.3m x 5.8	5.7		5.6	5.6					5.8	5.8				5.8		5.8	5.8
54.0			5.4		5.4	5.4					5.5	5.5				5.5		5.4m x 5.7	5.4
56.0			5.0		54.2m x 5.3	5.0					55.2m x 5.3	5.1				5.1			5.1
58.0			4.8			4.8										4.9			
60.0			59.8m x 4.6			4.6													
62.0						4.4													
64.0						62.7m x 4.3													

Luffing Jib Crane

CCH2000

■ Jib rated lifting loads (78ton counterweight, 16ton weight for body)

(Unit: metric ton)

Post length (m)		54.0														
Jib length (m)		36.0			39.0			42.0			45.0			48.0		
Working radius (m)	Post angle	90°	80°	70°	90°	80°	70°	90°	80°	70°	90°	80°	70°	90°	80°	70°
	9.0	9.8m x 23.5														
10.0	23.5				10.3m x 21.5			10.9m x 19.0			11.4m x 15.5			11.9m x 14.0		
12.0	23.5				21.5			19.0			15.5			14.0		
14.0	14.8m x 23.5				15.1m x 21.5			19.0			15.5			14.0		
16.0	22.4				21.0			16.7m x 19.0			15.5			14.0		
18.0	20.6				19.8			18.8			19.1m x 15.5			14.0		
20.0	19.4				18.6			18.4			15.4			13.5		
22.0	18.4				17.6			17.4			15.0			13.0		
24.0	17.6	25.2m x 17.1			16.8			16.5			14.6			12.6		
26.0	16.8	16.8			15.7	26.2m x 15.7		15.5	27.2m x 15.0		14.0			12.2		
28.0	16.1	16.1			15.0	15.0		14.7	14.7		13.2	28.2m x 13.2		11.7	29.3m x 11.4	
30.0	14.4	14.4			14.5	14.5		14.1	14.1		12.7	12.7		11.2	11.2	
32.0	13.1	13.1			13.1	13.1		13.1	13.1		12.0	12.0		10.5	10.5	
34.0	11.5	11.5			11.7	11.7		11.8	11.8		11.3	11.3		9.9	9.9	
36.0	9.9	9.9			10.4	10.4		10.7	10.7		10.6	10.6		9.4	9.4	
38.0	36.9m x 9.3	8.7	39.8m x 8.3		9.2	9.2		9.6	9.6		9.7	9.7		8.7	8.7	
40.0		8.3	8.3	39.7m x 8.3	8.2	41.3m x 7.9		8.5	8.5		8.8	8.8		8.1	8.1	
42.0		7.9	7.9		7.7	7.7		7.6	7.6	42.8m x 7.3	8.0	8.0		7.6	7.6	
44.0		7.4	7.4		7.3	7.3		7.4	7.4	42.5m x 7.4	7.0	7.0		7.1	7.1	45.8m x 6.5
46.0		7.0	7.0		6.8	6.8		6.7	6.7		6.5	6.5	44.3m x 6.9	6.5	6.5	6.5
48.0		46.2m x 6.9	6.5		6.4	6.4		6.3	6.3		6.2	6.2	45.3m x 6.7	6.2	6.2	5.8
50.0			6.1		49.1m x 6.2	6.1		6.0	6.0		5.9	5.9		5.8	48.2m x 5.8	5.5
52.0			5.7			5.7		5.7	5.7		5.6	5.6		5.3	5.3	
54.0			5.4			5.4		5.4	5.4		5.4	5.4		5.1	5.1	
56.0			55.2m x 5.2			5.0		5.0	5.0		5.0	5.0	54.7m x 5.3	5.0	4.8	4.8
58.0						4.8			4.8			4.8			57.5m x 4.6	4.5
60.0									4.6			4.6				4.3
62.0									60.9m x 4.5			4.4				4.0
64.0												63.7m x 4.2				3.8
66.0																3.6
68.0																66.5m x 3.5

Post length (m)		57.0																
Jib length (m)		27.0				30.0				33.0			36.0			39.0		
Working radius (m)	Post angle	90°	80°	70°	60°	90°	80°	70°	60°	90°	80°	70°	90°	80°	70°	90°	80°	70°
	8.0	8.3m x 25.0					8.8m x 25.0											
9.0	25.0					25.0				9.3m x 25.0			9.8m x 23.5					
10.0	25.0					25.0				25.0			23.5			10.3m x 21.5		
12.0	25.0					25.0				25.0			23.5			21.5		
14.0	15.1m x 25.0					14.3m x 25.0				25.0			14.8m x 23.5			15.1m x 21.5		
16.0	24.6					23.6				23.2			22.4			21.0		
18.0	23.7					22.0				21.6			20.6			19.8		
20.0	22.9					21.0				20.3			19.4			18.6		
22.0	21.5	22.6m x 20.8			20.0	23.6m x 19.3				19.3			18.4			17.6		
24.0	19.2	19.2			19.2	19.2				18.4	24.7m x 18.3		17.6	25.7m x 16.9		16.8		
26.0	16.0	16.0			17.9	17.9				18.0	18.0		16.8	16.8		15.7	26.7m x 15.5	
28.0	13.6	13.6			15.7	15.7				16.2	16.2		16.1	16.1		15.0	15.0	
30.0	28.4m x 13.4	12.1			12.6	12.6				14.1	14.1		14.4	14.4		14.5	14.5	
32.0		11.2				31.3m x 11.7	11.1			12.1	12.1		13.1	13.1		13.1	13.1	
34.0		10.7				10.5				10.5	10.5		11.5	11.5		11.7	11.7	
36.0		10.1	36.3m x 10.0			9.9	37.8m x 9.4			34.1m x 10.5	9.4		9.9	9.9		10.4	10.4	
38.0		9.5	9.5			9.4	9.4			9.0	39.3m x 8.7		36.9m x 9.3	8.7		9.2	9.2	
40.0		38.3m x 9.4	8.7			8.5	8.5			8.5	8.5		8.3	8.3	40.8m x 8.2	39.7m x 8.3	8.2	
42.0			8.2			41.1m x 8.2	8.0			8.0	8.0		7.9	7.9		7.7	42.3m x 7.7	
44.0			7.6				7.5			7.5	7.5		7.4	7.4		7.3	7.3	
46.0			7.2				7.0			7.0	7.0		7.0	7.0		6.8	6.8	
48.0			47.8m x 6.8	48.9m x 6.3			6.6			6.6	6.6		46.8m x 6.8	6.5		6.4	6.4	
50.0				6.2			6.2	50.9m x 6.0			6.2			6.1		49.6m x 6.2	6.1	
52.0				5.8			5.8	50.7m x 6.1	5.8		5.8			5.7			5.7	
54.0				5.5			5.5				53.5m x 5.6			5.4			5.4	
56.0				5.1			5.1							5.0			5.0	
58.0				56.7m x 5.0			4.9							56.3m x 5.0			4.8	
60.0							59.5m x 4.7										59.1m x 4.7	

Luffing Jib Crane

GCH2000

Jib rated lifting loads (78ton counterweight, 16ton weight for body)

(Unit:metric ton)

Post length (m)		57.0												60.0										
Jib length (m)		42.0			45.0			48.0			51.0			27.0				30.0						
Post angle		90°			80°			70°			90°			80°			70°				60°			
Working radius (m)		90°	80°	70°	90°	80°	70°	90°	80°	70°	90°	80°	70°	90°	80°	70°	60°	90°	80°	70°	60°			
8.0																								
9.0																								
10.0	10.9m x 19.0				11.4m x 15.5			11.9m x 14.0																
12.0	19.0				15.5			14.0																
14.0	19.0				15.5			14.0																
16.0	16.7m x 19.0				15.5			14.0																
18.0	18.8				19.1m x 15.5			14.0																
20.0	18.4				15.4			13.5																
22.0	17.4				15.0			13.0																
24.0	16.5				14.6			12.6																
26.0	15.5				14.0			12.2																
28.0	14.7	27.7m x 14.8			13.2			11.7	29.8m x 13.0															
30.0	14.1	14.1			12.7	12.7		11.2	11.2															
32.0	13.1	13.1			12.0	12.0		10.5	10.5															
34.0	11.8	11.8			11.3	11.3		9.9	9.9															
36.0	10.7	10.7			10.6	10.6		9.4	9.4															
38.0	9.6	9.6			9.7	9.7		8.7	8.7															
40.0	8.5	8.5			8.8	8.8		8.1	8.1															
42.0	7.6	7.6	43.8m x 7.0		8.0	8.0		7.6	7.6															
44.0	42.5m x 7.4	7.0	7.0	7.0	7.0	45.3m x 6.7		7.1	7.1															
46.0		6.7	6.7	45.3m x 6.7	6.5	6.5	6.5	6.5	46.8m x 6.2															
48.0		6.3	6.3		6.2	6.2	5.8	5.8	5.8	5.2	5.7	48.3m x 5.6												
50.0		6.0	6.0		5.9	5.9	48.2m x 5.8	5.5	5.5	5.5	4.7	5.3	5.3											
52.0		5.7	5.7		5.6	5.6		5.3	5.3	5.1	5.0	5.0	5.0											
54.0		52.4m x 5.6	5.4		5.4	5.4		5.1	5.1															
56.0			5.0		55.2m x 5.2	5.0		4.8	4.8															
58.0			4.8			4.8		4.5	4.5															
60.0			4.6			4.6		4.3	4.3															
62.0			4.4			4.4		4.0	4.0															
64.0						4.2		3.8	3.8															
66.0						64.7m x 4.1		3.6	3.6															
68.0								67.5m x 3.5																
70.0																								
72.0																								

Post length (m)		60.0																										
Jib length (m)		33.0			36.0			39.0			42.0			45.0			48.0			51.0								
Post angle		90°			80°			70°			90°			80°			70°			90°			80°			70°		
Working radius (m)		90°	80°	70°	90°	80°	70°	90°	80°	70°	90°	80°	70°	90°	80°	70°	90°	80°	70°	90°	80°	70°	90°	80°	70°			
9.0	9.3m x 25.0				9.8m x 23.5																							
10.0	25.0				23.5			10.3m x 21.5			10.9m x 19.0			11.4m x 15.5								11.9m x 14.0						
12.0	25.0				23.5			21.5			19.0			15.5								14.0						
14.0	25.0				14.8m x 23.5			15.1m x 21.5			19.0			15.5								14.0						
16.0	23.2				22.4			21.0			16.7m x 19.0			15.5								14.0						
18.0	21.6				20.6			19.8			18.8			19.1m x 15.5								14.0						
20.0	20.3				19.4			18.6			18.4			15.4								13.5						
22.0	19.3				18.4			17.6			17.4			15.0								13.0						
24.0	18.4	25.2m x 18.1			17.6			16.8			16.5			14.6								12.6						
26.0	18.0	18.0			16.8	26.2m x 16.7		15.7	27.2m x 15.3				15.5									12.2						
28.0	16.2	16.2			16.1	16.1		15.0	15.0				14.7	28.3m x 14.6								11.7						
30.0	14.1	14.1			14.4	14.4		14.5	14.5				14.1	14.1								11.2						
32.0	12.1	12.1			13.1	13.1		13.1	13.1				13.1	13.1								10.5	10.5					
34.0	10.5	10.5			11.5	11.5		11.7	11.7				11.8	11.8								9.9	9.9					
36.0	34.1m x 10.5	9.4			9.9	9.9		10.4	10.4				10.7	10.7								9.4	9.4					
38.0		9.0			36.9m x 9.3	8.7		9.2	9.2				9.6	9.6								8.7	8.7					
40.0		8.5	40.3m x 8.4		8.3	41.8m x 7.9	39.7m x 8.3	8.2					8.5	8.5								8.1	8.1					
42.0		8.0	8.0		7.9	7.9		7.7	43.3m x 7.4				7.6	7.6								7.6	7.6					
44.0		7.5	7.5		7.4	7.4		7.3	7.3	42.5m x 7.4			7.0	44.8m x 6.9								7.1	7.1					
46.0		44.5m x 7.4	7.0		7.0	7.0		6.8	6.8				6.7	6.7	45.3m x 6.7							6.5	6.5					
48.0			6.6		47.4m x 6.6	6.5		6.4	6.4				6.3	6.3	6.2	6.2	5.8	5.8	5.8	5.8	5.2	5.7	5.7					
50.0			6.2			6.1		6.1	6.1	50.2m x 6.0			6.0	6.0	5.9	5.9	48.2m x 5.8	5.5	5.5	4.7	5.3	5.3	5.3					
52.0			5.8			5.7		5.7	5.7				5.7	5.7	5.6	5.6						5.3	5.3					
54.0			5.5			5.4		5.4	5.4				5.4	5.4	5.4	5.4						5.1	5.1					
56.0			54.5m x 5.4			5.0		5.0	5.0				5.0	5.0	55.8m x 5.1							4.8	4.8					
58.0						57.4m x 4.9		4.8	4.8				4.8	4.8								4.5	4.5					
60.0								4.6	4.6				4.6	4.6								58.6m x 4.4	4.3					
62.0								60.2m x 4.6					4.4	4.4								4.0	4.0					
64.0													63.0m x 4.3									3.8	3.8					
66.0																						68.6m x 3.3	3.6					
68.0																							3.4					
70.0																							71.5m x 2.9					
72.0																												

Luffing Tower Crane

CCH2000

Specifications

Max. Lifting capacity x working radius		25.0metric tons x 15.1m
Max. lift above ground level		105.0m(60m post+51m jib)
Rope speed	Main drum hoist/lowering	* 110~55/55~28m/min
	Post hoist/lowering	* 32~14m/min x 2
	Jib hoist/lowering	* 110~55/55~28m/min
Part line	Main drum	Hook block capacity x Part line
	hoist	Hook block capacity x Part line
	Post hoist	13.5ton x 1
	Jib hoist	18
Counterweight		78ton
Weight for body		16ton
Total operating weight (with 60m post+51m jib+25ton hook)		211ton
Average ground bearing pressure		113kPa(1.15kg/cm ²)

Note: The rope speed changes depending on the load.

Combination of post and Jib

Jib length (m)	27	30	33	36	39	42	45	48	51
Post length (m)									
36	●	●	●	●	●	●	●	●	●
39	●	●	●	●	●	●	●	●	●
42	●	●	●	●	●	●	●	●	●
45	●	●	●	●	●	●	●	●	●
48	●	●	●	●	●	●	●	●	●
51	●	●	●	●	●	●	●	●	●
54	●	●	●	●	●	●	●	●	●
57	●	●	●	●	●	●	●	●	●
60	●	●	●	●	●	●	●	●	●

Note: ●:Possible combinations

Wire Rope

Place of use	Rope diameter (mm)	Guaranteed strength (t)	Rope type
Hook hoist	φ 28	70.2	P•S(19)+39 x P.7
Jib hoist	φ 26	61.0	P•S(19)+39 x P.7
Post hoist	φ 22	36.3	IWRC6 x P•WS(31)
Jib suspension	φ 34	104.0	IWRC6 x P•WS(36)
Strut suspension	φ 34	104.0	IWRC6 x P•WS(36)
Post suspension	φ 34	104.0	IWRC6 x P•WS(36)

Luffing tower crane post composition

The following table shows standard combinations of post lengths when ordering the maximum post length specification (60m).

Post length (m)	36.0	39.0	42.0	45.0	48.0	51.0	54.0	57.0	60.0
Post composition									
7.5m inner	1	1	1	1	1	1	1	1	1
* 3.0m insert	1	1	1	1	1	1	1	1	1
* 3.0m insert	1	1	1	1	1	1	1	1	1
3.0m insert	—	—	1	—	—	1	—	1	2
6.0m insert	1	—	—	1	—	—	1	1	1
9.0m insert	1	2	2	2	3	3	3	3	3
1.5m outer	1	1	1	1	1	1	1	1	1

Notes:

(*1) 9.0m and 3.0m insert posts with the * mark include guardrails for the middle equalizer.

(*2) A pendant cable for extending the jib is also included with the 3.0m-9.0m insert posts.

Jib composition

The following table shows standard combinations of jib lengths when ordering the maximum jib length specification.

Jib length (m)	27	30	33	36	39	42	45	48	51
Jib composition									
* 9.0m inner	1	1	1	1	1	1	1	1	1
* 3.0m insert	—	1	—	—	1	—	1	—	1
6.0m insert	—	—	1	—	—	1	1	2	2
9.0m insert	1	1	1	2	2	2	2	2	2
9.0m outer	1	1	1	1	1	1	1	1	1

Notes on 1m Auxiliary Jib

1. 1m Auxiliary Jib is fitted on the main boom length of 18 meter and up to 81 meter.

2. 1m Auxiliary Jib is to be used only for crane operation.

Working range (No load condition)

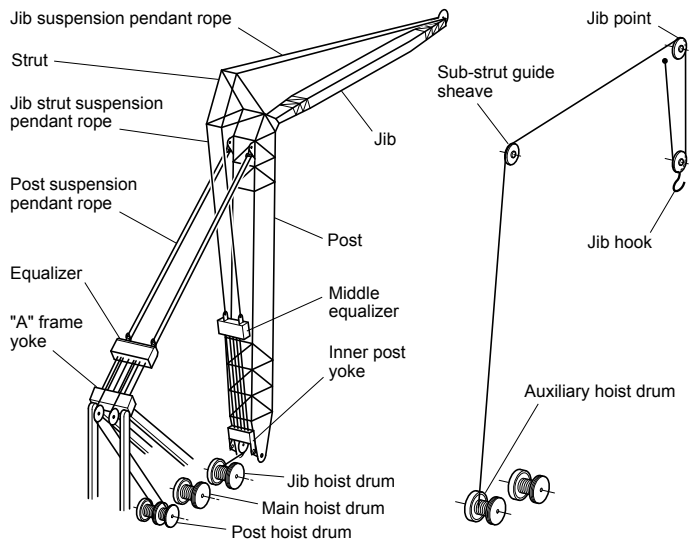
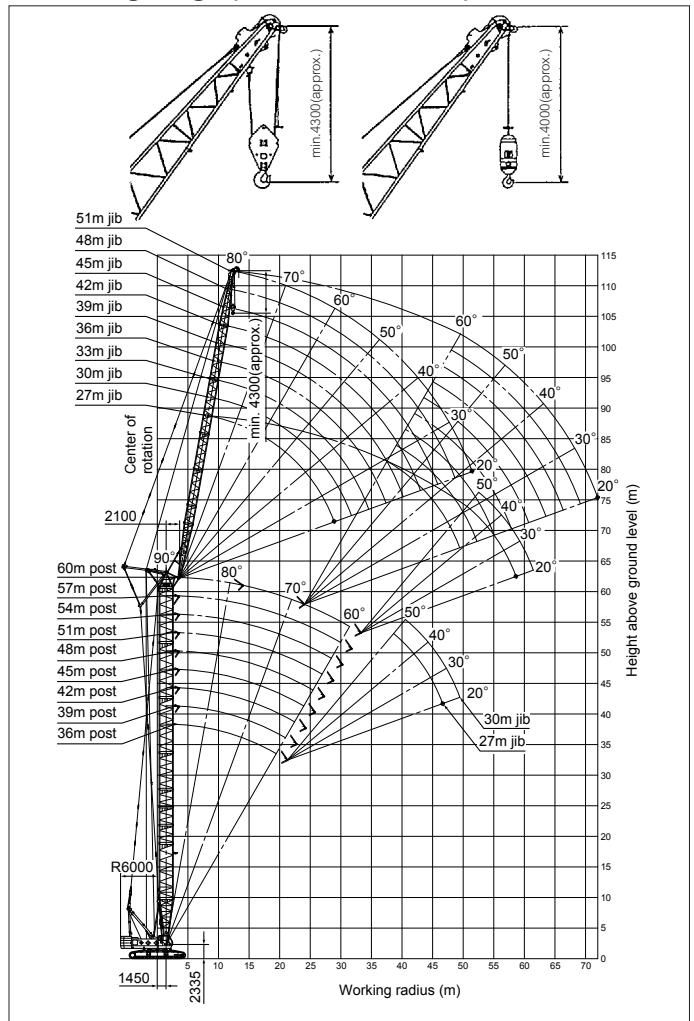

Luffing Tower Crane

CCH2000

■ Jib rated lifting loads (78ton counterweight, 16ton weight for body)

(Unit: metric ton)

Post length (m)	36.0								39.0											
Jib length (m)	27.0				30.0				27.0				30.0				33.0			
Post angle Working radius (m)	90°	80°	70°	60°	90°	80°	70°	60°	90°	80°	70°	60°	90°	80°	70°	60°	90°	80°	70°	
8.0	8.3m x 25.0				8.8m x 25.0				8.3m x 25.0				8.8m x 25.0							
9.0	25.0				25.0				25.0				25.0				9.3m x 25.0			
10.0	25.0				25.0				25.0				25.0				25.0			
12.0	25.0				25.0				25.0				25.0				25.0			
14.0	15.1m x 25.0				14.3m x 25.0				15.1m x 25.0				14.3m x 25.0				25.0			
16.0	24.6				23.6				24.6				23.6				23.2			
18.0	23.7	19.0m x 23.3			22.0				23.7	19.5m x 23.0			22.0				21.6			
20.0	22.9	22.9			21.0	21.0			22.9	22.9			21.0	20.5m x 20.8			20.3	21.5m x 19.6		
22.0	21.5	21.5			20.0	20.0			21.5	21.5			20.0	20.0			19.3	19.3		
24.0	19.2	19.2			19.2	19.2			19.2	19.2			19.2	19.2			18.4	18.4		
26.0	16.0	16.0			17.9	17.9			16.0	16.0			17.9	17.9			18.0	18.0		
28.0	13.6	13.6	29.1m x 12.8		15.7	15.7			13.6	13.6			15.7	15.7			16.2	16.2		
30.0	28.4m x 13.4	12.1	12.1		12.6	12.6	30.6m x 12.2		28.4m x 13.4	12.1	30.1m x 12.1		12.6	12.6	31.6m x 11.5		14.1	14.1		
32.0		11.2	11.2		31.3m x 11.7	11.1	11.1			11.2	11.2		31.3m x 11.7	11.1	11.1		12.1	12.1	33.1m x 11.2	
34.0		10.7	10.7			10.5	10.5			10.7	10.7			10.5	10.5		10.5	10.5	10.5	
36.0		34.7m x 10.5	10.1			9.9	9.9			35.2m x 10.3	10.1			9.9	9.9		34.1m x 10.5	9.4	9.4	
38.0			9.5	38.4m x 9.3		37.5m x 9.5	9.4				9.5	39.9m x 8.8		9.4	9.4			9.0	9.0	
40.0			8.7	8.7			8.5	40.4m x 8.4			8.7	8.7			8.5	41.9m x 8.0		8.5	8.5	
42.0			40.6m x 8.6	8.2			8.0	8.0			41.6m x 8.3	8.2		8.0	8.0		40.8m x 8.3	8.0	8.0	
44.0				7.6			43.4m x 7.6	7.5			7.6	7.6			7.5	7.5		7.5	7.5	
46.0				7.2				7.0			7.2	7.2			44.4m x 7.4	7.0			7.0	
48.0				46.1m x 7.2				6.6			47.6m x 6.8					6.6			47.3m x 6.7	
50.0								49.0m x 6.4								6.2				
52.0																50.5m x 6.1				

Post length (m)	42.0												45.0							
Jib length (m)	27.0				30.0				33.0				36.0				27.0			
Post angle Working radius (m)	90°	80°	70°	60°	90°	80°	70°	60°	90°	80°	70°	90°	80°	70°	90°	80°	70°	60°		
8.0	8.3m x 25.0				8.8m x 25.0										8.3m x 25.0					
9.0	25.0				25.0				9.3m x 25.0			9.8m x 23.5			25.0					
10.0	25.0				25.0				25.0			23.5			25.0					
12.0	25.0				25.0				25.0			23.5			25.0					
14.0	15.1m x 25.0				14.3m x 25.0				25.0			14.8m x 23.5			15.1m x 25.0					
16.0	24.6				23.6				23.2			22.4			24.6					
18.0	23.7				22.0				21.6			20.6			23.7					
20.0	22.9	22.9			21.0	21.0m x 20.5			20.3			19.4			22.9	20.5m x 22.5				
22.0	21.5	21.5			20.0	20.0			19.3	22.1m x 19.3		18.4	23.1m x 18.0		21.5	21.5				
24.0	19.2	19.2			19.2	19.2			18.4	18.4		17.6	17.6		19.2	19.2				
26.0	16.0	16.0			17.9	17.9			18.0	18.0		16.8	16.8		16.0	16.0				
28.0	13.6	13.6			15.7	15.7			16.2	16.2		16.1	16.1		13.6	13.6				
30.0	28.4m x 13.4	12.1	31.2m x 11.6		12.6	12.6			14.1	14.1		14.4	14.4		28.4m x 13.4	12.1				
32.0		11.2	11.2		31.3m x 11.7	11.1	32.7m x 10.9		12.1	12.1		13.1	13.1		11.2	32.2m x 11.2				
34.0		10.7	10.7			10.5	10.5		10.5	10.5	34.2m x 10.5	11.5	11.5	35.7m x 10.1		10.7	10.7			
36.0		35.7m x 10.2	10.1			9.9	9.9		34.1m x 10.5	9.4	9.4	9.9	9.9	9.9		10.1	10.1			
38.0			9.5			9.4	9.4			9.0	9.0	36.9m x 9.3	8.7	8.7		36.2m x 10.0	9.5			
40.0			8.7	41.4m x 8.3		38.5m x 9.1	8.5			8.5	8.5		8.3	8.3			8.7			
42.0			8.2	8.2			8.0	43.4m x 7.7		41.3m x 8.2	8.0		7.9	7.9			8.2	42.9m x 7.9		
44.0			42.7m x 8.0	7.6			7.5	7.5		7.5	7.5		7.4	7.4			43.7m x 7.7	7.6		
46.0				7.2			45.5m x 7.1	7.0		7.0	7.0		44.1m x 7.4	7.0				7.2		
48.0				6.7				6.6			6.6			6.5				6.7		
50.0				49.1m x 6.4				6.2			48.3m x 6.5			6.1				6.2		
52.0								5.8						51.1m x 5.9				50.6m x 6.1		

Luffing Tower Crane

CCH2000

■ Jib rated lifting loads (78ton counterweight, 16ton weight for body)

(Unit: metric ton)

Post length (m)	45.0															48.0			
Jib length (m)	30.0				33.0			36.0			39.0			27.0					
Post angle Working radius (m)	90°	80°	70°	60°	90°	80°	70°	90°	80°	70°	90°	80°	70°	90°	80°	70°	60°		
8.0	8.8m x 25.0																	8.3m x 25.0	
9.0	25.0				9.3m x 25.0			9.8m x 23.5										25.0	
10.0	25.0				25.0			23.5						10.3m x 21.5				25.0	
12.0	25.0				25.0			23.5						21.5				25.0	
14.0	14.3m x 25.0				25.0			14.8m x 23.5						15.1m x 21.5				15.1m x 25.0	
16.0	23.6				23.2			22.4						21.0				24.6	
18.0	22.0				21.6			20.6						19.8				23.7	
20.0	21.0	21.6m x 20.2			20.3			19.4						18.6				22.9	
22.0	20.0	20.0			19.3	22.6m x 19.0		18.4	23.6m x 17.8					17.6				21.5	
24.0	19.2	19.2			18.4	18.4		17.6	17.6					16.8	24.6m x 16.4			19.2	
26.0	17.9	17.9			18.0	18.0		16.8	16.8					15.7	15.7			16.0	
28.0	15.7	15.7			16.2	16.2		16.1	16.1					15.0	15.0			13.6	
30.0	12.6	12.6			14.1	14.1		14.4	14.4					14.5	14.5			12.1	
32.0	31.3m x 11.7	11.1	33.7m x 10.6		12.1	12.1		13.1	13.1					13.1	13.1			11.2	
34.0		10.5	10.5		10.5	10.5	35.2m x 9.9	11.5	11.5					11.7	11.7			10.7	
36.0		9.9	9.9		34.1m x 10.5	9.4	9.4	9.9	9.9	36.7m x 9.4				10.4	10.4			10.1	
38.0		9.4	9.4			9.0	9.0	36.9m x 9.3	8.7	8.7				9.2	9.2	38.2m x 9.1		9.5	
40.0		39.0m x 9.0	8.5			8.5	8.5		8.3	8.3	39.7m x 8.3			8.2	8.2			8.7	
42.0			8.0			41.8m x 8.1	8.0		7.9	7.9				7.7	7.7			8.2	
44.0			7.5	44.9m x 7.3			7.5		7.4	7.4				7.3	7.3			7.6	
46.0			7.0	7.0			7.0		44.7m x 7.3	7.0				6.8	6.8			44.7m x 7.5	
48.0			46.5m x 6.9	6.6			6.6							47.5m x 6.5	6.4			6.7	
50.0				6.2			49.3m x 6.3							6.1				6.2	
52.0				5.8										5.7				5.8	
54.0				53.5m x 5.6										52.1m x 5.7				52.1m x 5.8	
56.0															55.0m x 5.2				

Post length (m)	48.0																
Jib length (m)	30.0				33.0			36.0			39.0			42.0			
Post angle Working radius (m)	90°	80°	70°	60°	90°	80°	70°	90°	80°	70°	90°	80°	70°	90°	80°	70°	
8.0	8.8m x 25.0																
9.0	25.0				9.3m x 25.0			9.8m x 23.5									
10.0	25.0				25.0			23.5						10.3m x 21.5			10.9m x 19.0
12.0	25.0				25.0			23.5						21.5			19.0
14.0	14.3m x 25.0				25.0			14.8m x 23.5						15.1m x 21.5			19.0
16.0	23.6				23.2			22.4						21.0			16.7m x 19.0
18.0	22.0				21.6			20.6						19.8			18.8
20.0	21.0				20.3			19.4						18.6			18.4
22.0	20.0	22.1m x 20.0			19.3	23.1m x 18.8		18.4						17.6			17.4
24.0	19.2	19.2			18.4	18.4		17.6	24.1m x 17.6					16.8	25.1m x 16.2		16.5
26.0	17.9	17.9			18.0	18.0		16.8	16.8					15.7	15.7		15.5
28.0	15.7	15.7			16.2	16.2		16.1	16.1					15.0	15.0		14.7
30.0	12.6	12.6			14.1	14.1		14.4	14.4					14.5	14.5		14.1
32.0	31.3m x 11.7	11.1			12.1	12.1		13.1	13.1					13.1	13.1		13.1
34.0		10.5	34.7m x 10.3		10.5	10.5		11.5	11.5					11.7	11.7		11.8
36.0		9.9	9.9		34.1m x 10.5	9.4	36.2m x 9.4	9.9	9.9	37.7m x 8.8				10.4	10.4		10.7
38.0		9.4	9.4			9.0	9.0	36.9m x 9.3	8.7	8.7				9.2	9.2	39.2m x 8.6	9.6
40.0		39.5m x 8.7	8.5			8.5	8.5		8.3	8.3	39.7m x 8.3			8.2	8.2		40.7m x 8.2
42.0			8.0			8.0	8.0		7.9	7.9				7.7	7.7		7.6
44.0			7.5			42.4m x 7.9	7.5		7.4	7.4				7.3	7.3	42.5m x 7.4	7.0
46.0			7.0	46.4m x 6.9			7.0		45.2m x 7.2	7.0				6.8	6.8		6.7
48.0			47.5m x 6.7	6.6			6.6							6.4	6.4		6.3
50.0				6.2			6.2							6.1			6.0
52.0				5.8			50.3m x 6.1							5.7			50.8m x 5.9
54.0				5.5										53.2m x 5.5			5.4
56.0				55.0m x 5.3											5.0		5.0
58.0																	4.8
60.0																	58.8m x 4.7

Luffing Tower Crane

CCH2000

■ Jib rated lifting loads (78ton counterweight, 16ton weight for body)

(Unit: metric ton)

Post length (m)	51.0																			
Jib length (m)	27.0				30.0				33.0				36.0				39.0			
Post angle	Working radius (m)																			
Working radius (m)	90°	80°	70°	60°	90°	80°	70°	60°	90°	80°	70°	60°	90°	80°	70°	60°	90°	80°	70°	60°
8.0	8.3m x 25.0				8.8m x 25.0															
9.0	25.0				25.0							9.3m x 25.0				9.8m x 23.5				
10.0	25.0				25.0							25.0				23.5			10.3m x 21.5	
12.0	25.0				25.0							25.0				23.5			21.5	
14.0	15.1m x 25.0				14.3m x 25.0							25.0				14.8m x 23.5			15.1m x 21.5	
16.0	24.6				23.6							23.2				22.4			21.0	
18.0	23.7				22.0							21.6				20.6			19.8	
20.0	22.9	21.6m x 21.7			21.0							20.3				19.4			18.6	
22.0	21.5	21.5			20.0	22.6m x 19.8						19.3	23.6m x 18.6			18.4			17.6	
24.0	19.2	19.2			19.2	19.2						18.4	18.4			17.6	24.6m x 17.4		16.8	25.7m x 15.9
26.0	16.0	16.0			17.9	17.9						18.0	18.0			16.8	16.8		15.7	15.7
28.0	13.6	13.6			15.7	15.7						16.2	16.2			16.1	16.1		15.0	15.0
30.0	28.4m x 13.4	12.1			12.6	12.6						14.1	14.1			14.4	14.4		14.5	14.5
32.0		11.2			31.3m x 11.7	11.1						12.1	12.1			13.1	13.1		13.1	13.1
34.0		10.7	34.2m x 10.6			10.5	35.7m x 10.0					10.5	10.5			11.5	11.5		11.7	11.7
36.0		10.1	10.1			9.9	9.9					34.1m x 10.5	9.4	37.2m x 9.2		9.9	9.9		10.4	10.4
38.0		37.2m x 9.7	9.5			9.4	9.4					9.0	9.0			36.9m x 9.3	8.7	38.7m x 8.5	9.2	9.2
40.0			8.7			8.5	8.5					8.5	8.5			8.3	8.3	39.7m x 8.3	8.2	40.2m x 8.1
42.0			8.2			40.1m x 8.5	8.0					8.0	8.0			7.9	7.9		7.7	7.7
44.0			7.6	45.9m x 7.2			7.5					42.9m x 7.8	7.5			7.4	7.4		7.3	7.3
46.0			45.7m x 7.2	7.2			7.0	47.9m x 6.6				7.0				45.7m x 7.1	7.0		6.8	6.8
48.0				6.7			6.6	6.6				6.6					6.5		6.4	6.4
50.0				6.2			48.6m x 6.5	6.2				6.2					6.1		48.5m x 6.3	6.1
52.0				5.8				5.8				51.4m x 5.9					5.7			5.7
54.0				53.6m x 5.5				5.5									5.4			5.4
56.0								5.1									54.2m x 5.3			5.0
58.0								56.5m x 5.1												57.0m x 4.9

Post length (m)	51.0												54.0						
Jib length (m)	42.0			45.0			27.0			30.0			33.0						
Post angle	Working radius (m)																		
Working radius (m)	90°	80°	70°	90°	80°	70°	90°	80°	70°	60°	90°	80°	70°	60°	90°	80°	70°		
8.0											8.3m x 25.0				8.8m x 25.0				
9.0											25.0				25.0		9.3m x 25.0		
10.0	10.9m x 19.0										25.0				25.0		25.0		
12.0	19.0										25.0				25.0		25.0		
14.0	19.0										15.1m x 25.0				14.3m x 25.0		25.0		
16.0	16.7m x 19.0										24.6				23.6		23.2		
18.0	18.8										23.7				22.0		21.6		
20.0	18.4										22.9				21.0		20.3		
22.0	17.4										21.5	22.1m x 21.3			20.0	23.1m x 19.5	19.3		
24.0	16.5										19.2	19.2			19.2	19.2	18.4	24.1m x 18.4	
26.0	15.5	26.7m x 15.2									16.0	16.0			17.9	17.9		18.0	18.0
28.0	14.7	14.7									13.6	13.6			15.7	15.7		16.2	16.2
30.0	14.1	14.1									28.4m x 13.4	12.1			12.6	12.6		14.1	14.1
32.0	13.1	13.1									11.2				31.3m x 11.7	11.1		12.1	12.1
34.0	11.8	11.8									10.7	35.3m x 10.3			10.5			10.5	10.5
36.0	10.7	10.7									10.1	10.1			9.9	36.8m x 9.7		34.1m x 10.5	9.4
38.0	9.6	9.6									37.8m x 9.5	9.5			9.4	9.4		9.0	38.3m x 8.9
40.0	8.5	8.5	41.7m x 7.7								8.7				8.5	8.5		8.5	8.5
42.0	7.6	7.6	7.6	8.0							43.2m x 7.4				40.6m x 8.4	8.0		8.0	8.0
44.0	42.5m x 7.4	7.0	7.0	7.0	7.0						7.6				7.5			43.4m x 7.7	7.5
46.0		6.7	6.7	45.3m x 6.7	6.5	6.5					7.2	47.4m x 6.8			7.0			7.0	7.0
48.0		6.3	6.3		6.2	6.2					46.8m x 7.0	6.7			6.6	49.4m x 6.3		6.6	6.6
50.0		6.0	6.0		5.9	5.9					6.2				49.6m x 6.3	6.2		6.2	6.2
52.0		51.3m x 5.8	5.7		5.6	5.6					5.8					5.8			5.8
54.0			5.4		5.4	5.4					5.5					5.5			52.4m x 5.7
56.0			5.0		54.2m x 5.3	5.0					5.5	55.2m x 5.3				5.1			
58.0			4.8			4.8										4.9			
60.0			59.8m x 4.6			4.6													
62.0						4.4													
64.0						62.7m x 4.3													

Luffing Tower Crane

CCH2000

■ Jib rated lifting loads (78ton counterweight, 16ton weight for body)

(Unit: metric ton)

Post length (m)		36.0						39.0			54.0			45.0			48.0		
Jib length (m)		36.0		39.0		42.0		45.0		48.0		48.0		48.0		48.0			
Working radius (m)	Post angle	90°	80°	70°	90°	80°	70°	90°	80°	70°	90°	80°	70°	90°	80°	70°			
	9.0	9.8m x 23.5																	
10.0	23.5				10.3m x 21.5			10.9m x 19.0			11.4m x 15.5			11.9m x 14.0					
12.0	23.5				21.5			19.0			15.5			14.0					
14.0	14.8m x 23.5				15.1m x 21.5			19.0			15.5			14.0					
16.0	22.4				21.0			16.7m x 19.0			15.5			14.0					
18.0	20.6				19.8			18.8			19.1m x 18.5			14.0					
20.0	19.4				18.6			18.4			15.4			13.5					
22.0	18.4				17.6			17.4			15.0			13.0					
24.0	17.6	25.2m x 17.1			16.8			16.5			14.6			12.6					
26.0	16.8	16.8			15.7	26.2m x 15.7		15.5	27.2m x 15.0		14.0			12.2					
28.0	16.1	16.1			15.0	15.0		14.7	14.7		13.2	28.2m x 13.2		11.7	29.3m x 11.4				
30.0	14.4	14.4			14.5	14.5		14.1	14.1		12.7	12.7		11.2	11.2				
32.0	13.1	13.1			13.1	13.1		13.1	13.1		12.0	12.0		10.5	10.5				
34.0	11.5	11.5			11.7	11.7		11.8	11.8		11.3	11.3		9.9	9.9				
36.0	9.9	9.9			10.4	10.4		10.7	10.7		10.6	10.6		9.4	9.4				
38.0	36.9m x 9.3	8.7	39.8m x 8.3		9.2	9.2		9.6	9.6		9.7	9.7		8.7	8.7				
40.0		8.3	8.3	39.7m x 8.3	8.2	41.3m x 7.9		8.5	8.5		8.8	8.8		8.1	8.1				
42.0		7.9	7.9		7.7	7.7		7.6	7.6	42.8m x 7.3	8.0	8.0		7.6	7.6				
44.0		7.4	7.4		7.3	7.3		7.0	7.0	42.5m x 7.4	7.0	7.0	44.3m x 6.9	7.1	7.1	45.8m x 6.5			
46.0		7.0	7.0		6.8	6.8		6.7	6.7		6.5	6.5	45.3m x 6.7	6.5	6.5	6.5			
48.0		46.2m x 6.9			6.5	6.5		6.4	6.4		6.2	6.2		5.8	5.8	5.8			
50.0					6.1	6.1	49.1m x 6.2		6.0	6.0		5.9	5.9	48.2m x 5.8	5.5	5.5			
52.0					5.7	5.7		5.7	5.7		5.6	5.6		5.3	5.3				
54.0					5.4	5.4		5.4	5.4		5.4	5.4		5.1	5.1				
56.0					5.2	5.2		5.0	5.0		5.0	5.0	54.7m x 5.3	5.0	5.0	4.8			
58.0								4.8	4.8			4.8		4.8	57.6m x 4.6	4.5			
60.0									4.6			4.6				4.3			
62.0									60.9m x 4.5			4.4				4.0			
64.0												63.7m x 4.2				3.8			
66.0																3.6			
68.0																66.5m x 3.5			

Post length (m)		27.0						30.0				33.0			36.0			39.0		
Jib length (m)		27.0		30.0		33.0		36.0		39.0		39.0		39.0		39.0				
Working radius (m)	Post angle	90°	80°	70°	60°	90°	80°	70°	60°	90°	80°	70°	90°	80°	70°	90°	80°	70°		
	8.0	8.3m x 25.0					8.8m x 25.0													
9.0	25.0					25.0				9.3m x 25.0			9.8m x 23.5							
10.0	25.0					25.0				25.0			23.5					10.3m x 21.5		
12.0	25.0					25.0				25.0			23.5					21.5		
14.0	15.1m x 25.0					14.3m x 25.0				25.0			14.8m x 23.5					15.1m x 21.5		
16.0	24.6					23.6				23.2			22.4					21.0		
18.0	23.7					22.0				21.6			20.6					19.8		
20.0	22.9					21.0				20.3			19.4					18.6		
22.0	21.5	22.6m x 20.8				20.0	23.6m x 19.3			19.3			18.4					17.6		
24.0	19.2	19.2				19.2	19.2			18.4	24.7m x 18.3		17.6	25.7m x 16.9				16.8		
26.0	16.0	16.0				17.9	17.9			18.0	18.0		16.8	16.8				15.7		
28.0	13.6	13.6				15.7	15.7			16.2	16.2		16.1	16.1				15.0		
30.0	28.4m x 13.4					12.6	12.6			14.1	14.1		14.4	14.4				14.5		
32.0						31.3m x 11.7				12.1	12.1		13.1	13.1				13.1		
34.0						10.5				10.5	10.5		11.5	11.5				11.7		
36.0						9.9	37.8m x 9.4			34.1m x 10.5	9.4		9.9	9.9				10.4		
38.0						9.4	9.4			9.0	39.3m x 8.7		36.9m x 9.3	8.7				9.2		
40.0						8.5	8.5			8.5	8.5		8.3	40.8m x 8.2			39.7m x 8.3			
42.0						8.2				8.0	8.0		7.9	7.9				7.7		
44.0						7.6				7.5	7.5		7.4	7.4				7.3		
46.0						7.2				7.0	7.0		7.0	7.0				6.8		
48.0						47.8m x 6.8	48.9m x 6.5			6.6			6.6	46.8m x 6.8				6.4		
50.0						6.2				6.2	50.9m x 6.0		6.2					49.6m x 6.2		
52.0						5.8				5.8			5.8					5.7		
54.0						5.5				5.5			53.5m x 5.6					5.4		
56.0						5.1				5.1								5.0		
58.0						56.7m x 5.0				4.9								56.3m x 5.0		
60.0										59.5m x 4.7								59.1m x 4.7		

Luffing Tower Crane

CCH2000

Jib rated lifting loads (78ton counterweight, 16ton weight for body)

(Unit:metric ton)

Post length (m)	57.0											60.0												
	42.0			45.0			48.0			51.0			27.0				30.0				33.0			
Jib length (m) Post angle Working radius (m)	90°	80°	70°	90°	80°	70°	90°	80°	70°	90°	80°	70°	90°	80°	70°	60°	90°	80°	70°	60°	90°	80°	70°	
8.0																								
9.0																	8.3m x 25.0				8.8m x 25.0			
10.0	10.9m x 19.0			11.4m x 15.5			11.9m x 14.0										25.0				25.0			9.3m x 25.0
12.0	19.0			15.5			14.0					12.4m x 13.1					25.0				25.0			25.0
14.0	19.0			15.5			14.0					13.1					15.1m x 25.0				14.3m x 25.0			25.0
16.0	16.7m x 19.0			15.5			14.0					13.1					24.6				23.6			23.2
18.0	18.8			15.5			14.0					13.1					23.7				22.0			21.6
20.0	18.4			15.4			13.5					12.8					22.9				21.0			20.3
22.0	17.4			15.0			13.0					12.4					21.5	23.1m x 20.2			20.0			19.3
24.0	16.5			14.6			12.6					12.0					19.2	19.2			19.2	24.2m x 19.0		18.4
26.0	15.5	27.7m x 14.8		14.0			12.2					11.5					16.0	16.0			17.9	17.9		18.0
28.0	14.7	14.7		13.2	28.8m x 13.0		11.7	29.8m x 11.2				11.0					13.6	13.6			15.7	15.7		16.2
30.0	14.1	14.1		12.7	12.7		11.2	11.2				10.4	30.8m x 10.2				12.1	12.1			12.6	12.6		14.1
32.0	13.1	13.1		12.0	12.0		10.5	10.5				9.8	9.9				11.2				31.3m x 11.7	11.1		12.1
34.0	11.8	11.8		11.3	11.3		9.9	9.9				9.1	9.4				10.7				10.5			10.5
36.0	10.7	10.7		10.6	10.6		9.4	9.4				8.5	8.9				10.1	37.3m x 9.7			9.9			9.4
38.0	9.6	9.6		9.7	9.7		8.7	8.7				7.8	8.3				9.5	9.5			9.4	38.8m x 9.0		9.0
40.0	8.5	8.5		8.8	8.8		8.1	8.1				7.3	7.8				38.9m x 9.1	8.7			8.5	8.5		8.5
42.0	7.6	7.6	43.8m x 7.0	8.0	8.0		7.6	7.6				6.7	7.2								41.7m x 8.1	8.0		8.0
44.0	42.5m x 7.4	7.0	7.0	7.0	45.3m x 6.7		7.1	7.1				6.2	6.5								7.6			7.5
46.0		6.7	6.7	45.3m x 6.7	6.5	6.5	6.5	6.5	46.8m x 6.2			5.7	6.1								7.2			7.0
48.0		6.3	6.3	6.2	6.2	5.8	5.8	5.8	5.2	5.7	48.3m x 5.6										6.7			6.6
50.0		6.0	6.0	5.9	5.9	48.2m x 5.8	5.5	5.5	4.7	5.3	5.3						48.9m x 6.5	50.4m x 6.1			6.2			6.2
52.0		5.7	5.7	5.6	5.6	5.3	5.3	5.1	5.0	5.0	51.0m x 4.4										5.8			5.8
54.0		5.4	5.4	5.4	5.4	5.1	5.1	4.8	4.8	4.8	4.8										5.5			5.5
56.0		5.0	5.0	5.0	5.0	4.8	4.8	4.5	4.5	4.5	4.5										5.1			5.1
58.0		4.8	4.8	4.8	4.8	4.5	4.5	4.2	4.2	4.2	4.2										4.9			4.9
60.0		4.6	4.6	4.6	4.6	4.3	4.3	4.0	4.0	4.0	4.0										58.2m x 4.9			4.7
62.0		4.4	4.4	4.4	4.4	4.0	4.0	3.8	3.8	3.8	3.8										61.0m x 4.5			4.4
64.0				4.2	4.2		3.8	3.8																4.2
66.0					64.7m x 4.1			3.6																3.4
68.0								67.5m x 3.5																3.2
70.0																								3.0
72.0																								70.3m x 3.0

Post length (m)	60.0																							
	36.0			39.0			42.0			45.0			48.0			51.0								
Jib length (m) Post angle Working radius (m)	90°	80°	70°	90°	80°	70°	90°	80°	70°	90°	80°	70°	90°	80°	70°	90°	80°	70°						
9.0	9.8m x 23.5																							
10.0	23.5			10.3m x 21.5			10.9m x 19.0			11.4m x 15.5			11.9m x 14.0											
12.0	23.5			21.5			19.0			15.5			14.0						12.4m x 13.1					
14.0	14.8m x 23.5			21.5			19.0			15.5			14.0						13.1					
16.0	22.4			21.0			16.7m x 19.0			15.5			14.0						13.1					
18.0	20.6			19.8			18.8			19.1m x 15.5			14.0						13.1					
20.0	19.4			18.6			18.4			15.4			13.5						12.8					
22.0	18.4			17.6			17.4			15.0			13.0						12.4					
24.0	17.6			16.8			16.5			14.6			12.6						12.0					
26.0	16.8	26.2m x 16.7		15.7	27.2m x 15.3		15.5			14.0			12.2						11.5					
28.0	16.1	16.1		15.0	15.0		14.7	26.3m x 14.8		13.2	29.3m x 12.9		11.7						11.0					
30.0	14.4	14.4		14.5	14.5		14.1	14.1		12.7	12.7		11.2	30.3m x 11.1		10.4	31.3m x 10.0							
32.0	13.1	13.1		13.1	13.1		13.1	13.1		12.0	12.0		10.5	10.5		9.8	9.9							
34.0	11.5	11.5		11.7	11.7		11.8	11.8		11.3	11.3		9.9	9.9		9.1	9.4							
36.0	9.9	9.9		10.4	10.4		10.7	10.7		10.6	10.6		9.4	9.4		8.5	8.9							
38.0	36.9m x 9.3	8.7		9.2	9.2		9.6	9.6		9.7	9.7		8.7	8.7		7.8	8.3							
40.0		8.3	41.8m x 7.9	39.7m x 6.3	8.2		8.5	8.5		8.8	8.8		8.1	8.1		7.3	7.8							
42.0		7.9	7.9	7.7	43.3m x 7.4		7.6	7.6		8.0	8.0		7.6	7.6		6.7	7.2							
44.0		7.4	7.4	7.3	7.3	42.5m x 7.4	7.0	44.8m x 6.9		7.0	7.0		7.1	7.1		6.2	6.5							
46.0		7.0	7.0	6.8	6.8	6.7	6.7	45.3m x 6.7		6.5	46.3m x 6.5		6.5	6.5	47.8m x 5.9	5.7	6.1							
48.0		47.4m x 6.6	6.5	6.4	6.4	6.3	6.3			6.2	6.2	5.8	5.8	5.2	5.7	49.3m x 5.4								
50.0			6.1	6.1	6.1	6.0	6.0			5.9	5.9	48.2m x 5.8	5.5	5.5	4.7	5.3	5.3							
52.0			5.7	5.0	5.0	5.7	5.7			5.6	5.6		5.3	5.3	51.0m x 4.4	5.0	5.0							
54.0			5.4		5.4		5.4	53.0m x 5.5		5.4	5.4		5.1	5.1		4.8	4.8							
56.0			5.0		5.0		5.0			5.0	5.0		5.0	4.8	4.8	4.5	4.5							
58.0			57.4m x 4.9		4.8		4.8			4.8	4.8		4.8	4.5	4.5	4.2	4.2							
60.0					4.6		4.6			4.6	4.6		4.6	58.8m x 4.4	4.3	4.0	4.0							
62.0						60.2m x 4.6		4.4		4.4	4.4		4.4		4.0	61.4m x 3.9	3.8							
64.0								63.0m x 4.3					4.2				3.6							
66.0													65.8m x 4.0				3.6						3.4	
68.0																		3.4					3.2	
70.0																							3.0	
72.0																								71.5m x 2.9

- Notes
- Above rated loads are based on firm level ground, within 78% of tipping load at any point of 360° throughout and with front stability of 1.15 or more.
 - The actual lifting loads must be reduced following hook block (main and jib) and other lifting devices.
For tower jib
25ton hook block...1.00ton
13.5ton hook block...0.60ton
 - Depending on the number of part lines, rated load is limited as follows:
1-part line...up to 13.5ton
2-part line...up to 25.0ton
 - The angle of the center line of the post and the center line of the jib (offset angle) must not be less than 10°.
 - The angle of the center line of the jib to level ground (tower jib angle) must not be less than 20° under loaded conditions.

Post Crane

GCH2000

■ Specifications

Max. lifting capacity x working radius		50.0metric tons x 14.0m
Max. lift above ground level		55.0m (at 57m post)
Rope speed	Main drum hoist/lowering	* 110~55/55~28m/min
	Post hoist/lowering	* 32~14m/min x 2
Part line	Main drum hoist	50ton x 4
	Hook block capacity x Part line	25ton x 2
	Post hoist	18
Counterweight		78.0ton
Weight for body		16.0ton
Total operating weight (with 57m post+50ton hook)		201.0ton
Average ground bearing pressure		108kPa(1.10kg/cm ²)

Note: The rope speed changes depending on the load.

■ Wire Rope

Place of use	Rope diameter (mm)	Guaranteed strength (ton)	Rope type
Main drum	φ 28	70.2	P•S(19)+39 x P7
Boom hoist	φ 22	36.3	IWRC6 x P•WS(31)
Boom suspension	φ 34	104.0	IWRC6 x P•WS(36)

■ Post crane composition

Post composition	Post length (m)													
	21	24	27	30	33	36	39	42	45	48	51	54	57	
7.5m inner	1	1	1	1	1	1	1	1	1	1	1	1	1	
✕ * 9.0m insert	1	1	1	1	1	1	1	1	1	1	1	1	1	
✕ * 3.0m insert	1	1	1	1	1	1	1	1	1	1	1	1	1	
3.0m insert	—	1	—	—	1	—	—	1	—	—	1	—	1	
6.0m insert	—	—	1	—	—	1	—	—	1	—	—	1	1	
9.0m insert	—	—	—	1	1	1	2	2	3	3	3	3	3	
1.5m outer	1	1	1	1	1	1	1	1	1	1	1	1	1	

Note: (*) 9.0m and 3.0m insert posts with the *mark include guardrails for the middle equalizer.

Notes

- Above rated loads are based on firm level ground, within 78% of tipping load at any point of 360° throughout and with front stability of 1.15 or more.
- Working radius is horizontal distance from center of rotation to a vertical line through the center of gravity of the load.
- The actual lifting loads must be reduced following hook block and other lifting devices.
50ton hook block.....1.00ton 30ton hook block.....1.00ton
13.5ton hook block.....0.6ton
- Depending on the number of part lines, rated lifting load is limited as follows:
1part line.....up to 13.5ton
2part line.....up to 25.0ton
3part line.....up to 37.5ton
4part line.....up to 50.0ton

■ Post rated lifting loads (78ton counterweight, 16ton weight for body)

(Unit:metric ton)

Boom length (m) \ Working radius (m)	21.0	24.0	27.0	30.0	33.0	36.0	39.0	42.0	45.0	48.0	51.0	54.0	57.0
6.0	6.9m x 50.0												
7.0	50.0	7.4m x 50.0	7.9m x 50.0										
8.0	50.0	50.0	50.0	8.4m x 50.0									
9.0	50.0	50.0	50.0	50.0	9.0m x 50.0	9.5m x 50.0							
10.0	50.0	50.0	50.0	50.0	50.0	50.0	10.0m x 50.0	10.5m x 50.0	11.0m x 50.0	11.6m x 50.0			
12.0	50.0	50.0	50.0	50.0	50.0	50.0	13.9m x 50.0	13.9m x 50.0	13.9m x 50.0	13.8m x 50.0	12.1m x 50.0	12.6m x 50.0	13.1m x 50.0
14.0	50.0	50.0	50.0	50.0	50.0	49.9	49.8	49.7	49.5	49.4	49.3	49.1	49.0
16.0	41.9	41.8	41.6	41.5	41.4	41.2	41.1	41.0	40.8	40.7	40.5	40.4	40.3
18.0	35.6	35.4	35.3	35.1	35.0	34.9	34.7	34.6	34.4	34.3	34.2	34.0	33.9
20.0	30.7	30.6	30.4	30.3	30.2	30.0	29.9	29.7	29.6	29.4	29.3	29.2	29.0
22.0	21.3m x 28.2	26.8	26.6	26.5	26.3	26.2	26.0	25.9	25.7	25.6	25.5	25.3	25.2
24.0		23.9m x 23.7	23.6	23.4	23.3	23.1	23.0	22.8	22.7	22.5	22.4	22.2	22.1
26.0			21.0	20.9	20.7	20.5	20.4	20.2	20.1	19.9	19.8	19.6	19.5
28.0				26.5m x 20.4	18.7	18.6	18.4	18.3	18.1	17.9	17.8	17.6	17.5
30.0					29.1m x 17.7	16.7	16.6	16.4	16.3	16.1	16.0	15.8	15.7
32.0						31.7m x 15.4	15.0	14.9	14.7	14.5	14.4	14.2	13.9
34.0							13.6	13.5	13.3	13.2	13.0	12.9	12.5
36.0							34.3m x 13.5	12.3	12.1	12.0	11.8	11.7	11.3
38.0								36.9m x 11.8	11.1	10.9	10.7	10.4	10.3
40.0									39.5m x 10.3	10.0	9.8	9.5	9.3
42.0										9.1	8.9	8.8	8.5
44.0										42.1m x 9.1	8.2	8.0	7.7
46.0											44.7m x 7.9	7.3	7.0
48.0												47.3m x 6.9	6.5
50.0													49.9m x 5.9
52.0													5.0

■ Working range (No load condition)

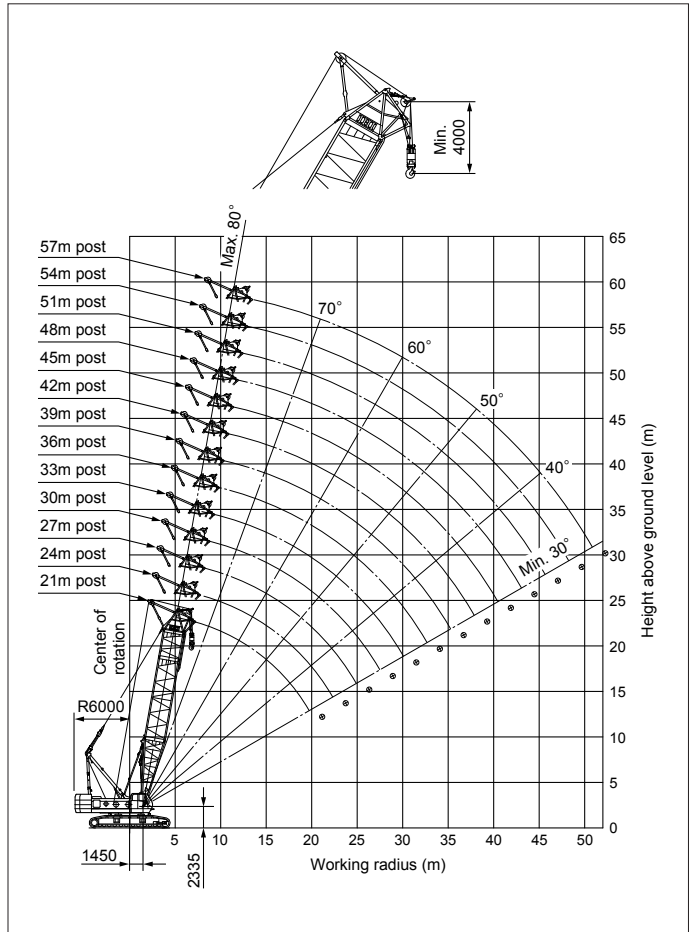

Specifications

Max. lift above ground		46.0m (18m boom+2.5m ³ bucket)
Rope speed	Bucket closing	* 110~55/55~28m/min
	Bucket holding	* 110~55/55~28m/min
	Boom hoist and lowering	* 32~14m/min x 2
Part line	Bucket closing	6 (for all types bucket)
	Bucket holding	1 (for all types bucket)
	Boom hoist	18
Rated lifting capacity		12.5ton (bucket weight+load)
Counterweight		78.0ton
Weight for body		16.0ton
Total operating weight (with 18m boom+2.5m ³ bucket)		196.0ton (Approx.)
Average ground bearing pressure		105kPa(1.07kg/cm ²)

*: The rope speed changes depending on the load.

Wire Rope

Place of use	Rope diameter (mm)	Guaranteed strength (ton)	Rope type
Bucket closing	φ 28	59.7	IWRC6 x Fi (29)
Bucket holding	φ 28	59.7	IWRC6 x Fi (29)
Boom hoist	φ 22	36.3	IWRC6 x P·WS(31)
Boom suspension	φ 34	104.0	IWRC6 x P·WS(36)
Tagline	φ 10	5.5	6 x 19

Length of wire rope to be decided according to the ordered boom length.

Bucket specifications

Classification	Capacity(m ³)	Weight (t)	Purpose
Optional	2.0	6.5	Heavy duty digging (dredging)
Standard	2.5	5.5	General digging, heavy material handling
Optional	3.0	5.0	Medium weight material handling (Apparent specific gravity: 1.2~1.5)
Optional	4.0	4.5	Lightweight material handling (Apparent specific gravity: less than 1.2)
Optional	5.0	4.0	Lightweight material handling (Apparent specific gravity: less than 1.0)

General Dimensions

Unit: mm

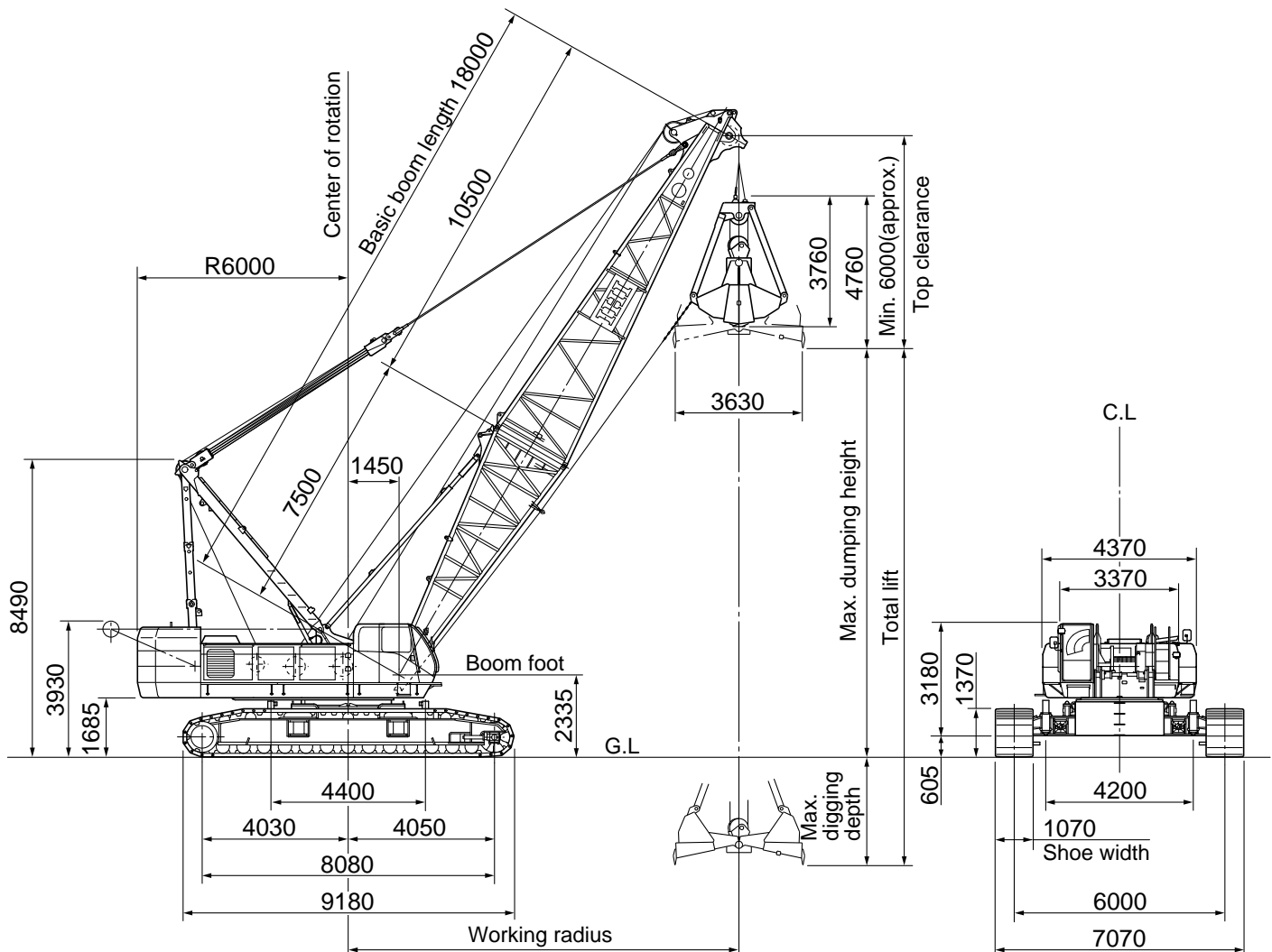

Working range (No load condition)

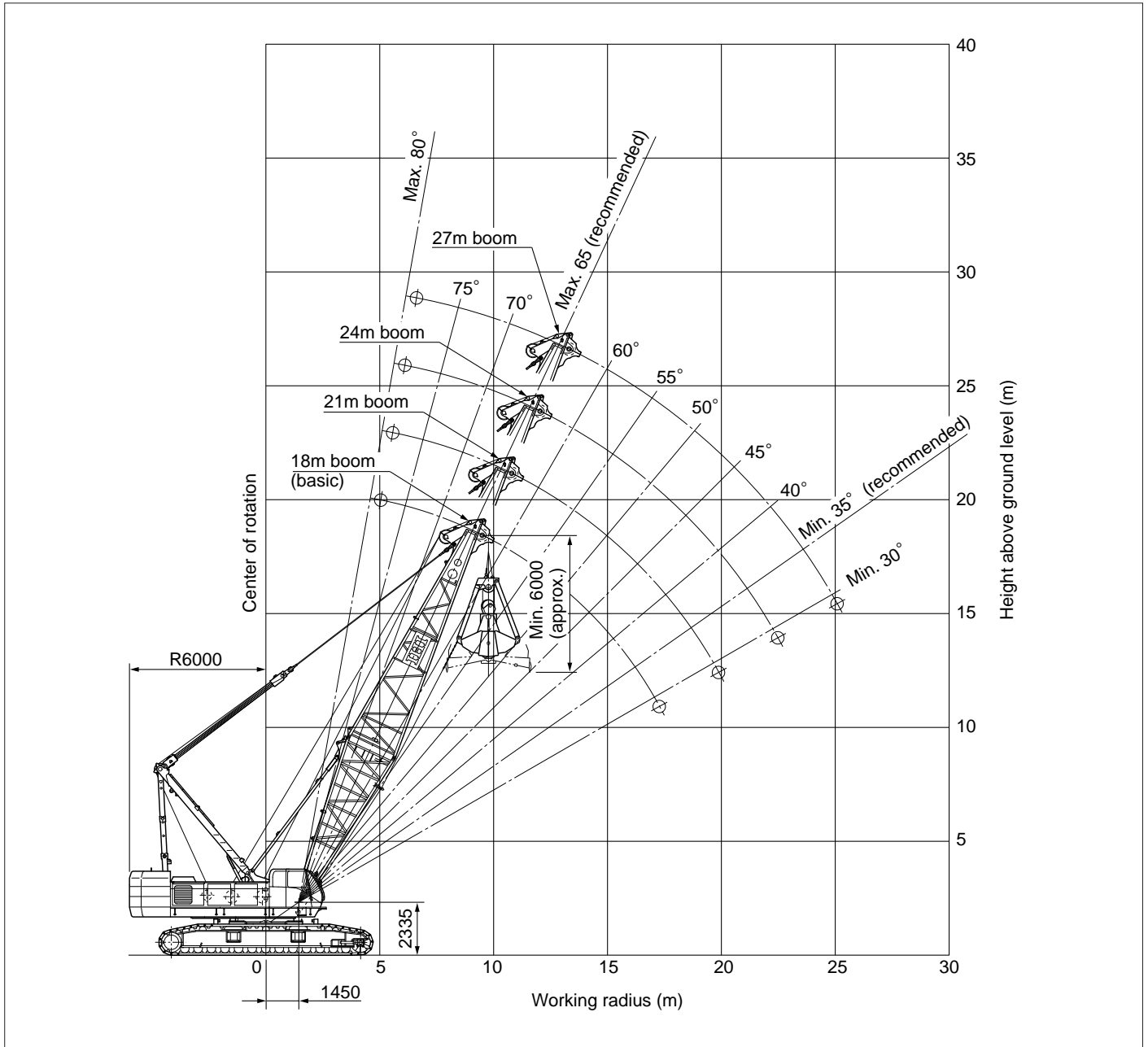

Working range and rated loads

Boom length (m)	18				21				24				27			
	35°	45°	55°	65°	35°	45°	55°	65°	35°	45°	55°	65°	35°	45°	55°	65°
Working radius (m)	16.7	14.7	12.4	9.7	19.2	16.9	14.1	11.0	21.6	19.0	15.8	12.2	24.1	21.1	17.5	13.5
Rated lifting load (ton)	12.5	12.5	12.5	12.5	12.5	12.5	12.5	12.5	12.5	12.5	12.5	12.5	12.5	12.5	12.5	12.5
Total lift (m)	12.3	14.8	16.9	18.5	14.1	16.9	19.3	21.2	15.8	19.0	21.8	23.9	17.5	21.1	24.2	26.6
Max. dumping height (m)	6.3	8.8	10.9	12.5	8.1	10.9	13.3	15.2	9.8	13.0	15.8	17.9	11.5	15.1	18.2	20.6
Max. digging depth (m)	39.7	37.2	35.1	33.5	37.9	35.1	32.7	30.8	36.2	33.0	30.2	28.1	34.5	30.9	27.8	25.4

Notes

- Recommended maximum boom length is 27m. Rated lifting load is the upper limit of "bucket weight+load" during clamshell work.
Use a bucket suitable for the kind of the load required so that the allowable load figures in the above table are not exceeded.
- Working radius is horizontal distance from center of rotation to a vertical line through the center of bucket.
"Maximum dumping height" is calculated 6m bucket clearance, therefore it will be decided by bucket size.
"Maximum digging depth" is deducted "Max. dumping height" from "Total lift" (46m).
- Bucket operation can not be performed by 1m jib.
- During the bucket lowering operation, half brake controlled free fall in permissible less than 10m, farther lowering to be use in combination with power load lowering.
- Allowable bucket weight is 6.5 ton, however, must be reduced bucket weight depend on duty cycle and total lift.
- During the slewing, do not give the lateral load to boom by hard acceleration or deceleration.
Operate most carefully when installed longer boom.

Pontoon mounted crane

CCH2000

■ Pontoon mounted crane specifications

Max. lifting capacity(metric ton) x working radius(m)		100 x 7.0 (360° throughout)
Max. boom length		36.0
Rope speed	Main drum hoist/lowering	* 110~0m/min
	Aux. drum hoist/lowering	* 110~0m/min
	Boom drum hoist/lowering	* 55~0m/min
Part line	Main drum hoist	100ton x 8
	Hook block capacity x part line	13.5ton x 1
	Boom drum hoist/lowering	18
Counterweight		64.0ton
Total operating weight with 18m boom (including crawler fixing device)		163.0ton
Average ground bearing pressure		87kPa(0.89kg/cm ²)

*: The rope speed changes depending on the load.

■ Wire Rope

Place of use	Rope diameter (mm)	Guaranteed strength (ton)	Rope type
Hook hoist	φ 28	67.0	IWRC6 x P•Fi (29)
Boom hoist	φ 22	36.3	IWRC6 x P•WS(31)
Boom suspension	φ 34	104.0	IWRC6 x P•WS(36)
Jib hoist	φ 28	67.0	IWRC6 x P•Fi (29)

■ General dimensions (Unit: mm)

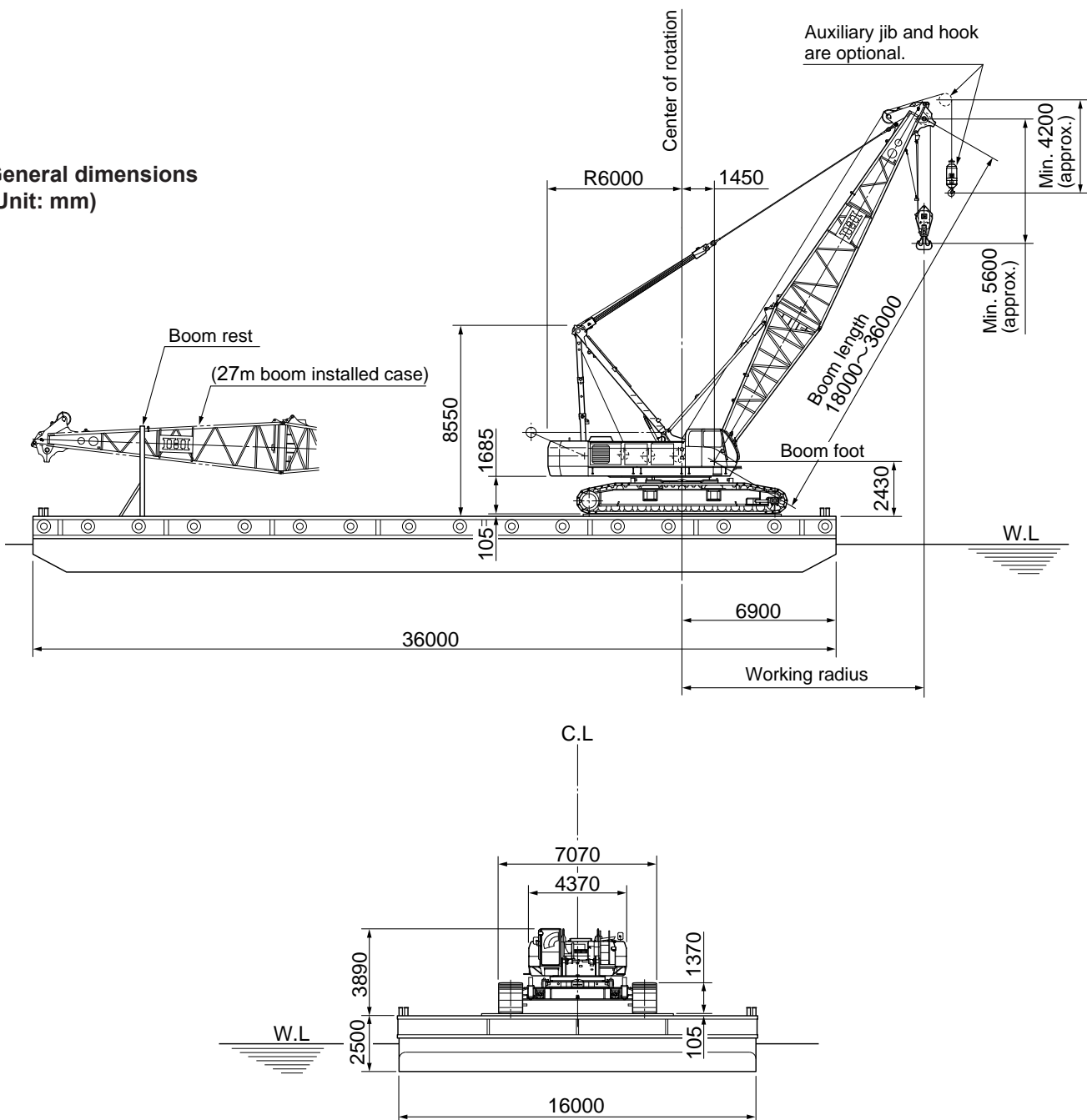

Above figure is for reference when CCH2000 crawler crane mounted on pontoon as floating crane.

Pontoon mounted crane

CCH2000

■ Main boom rated lifting loads

(Unit:metric ton)

Boom length (m)	18		21		24		27		30		33		36	
Working radius (m)	Load	Angle	Load	Angle	Load	Angle	Load	Angle	Load	Angle	Load	Angle	Load	Angle
5.0	100.0	80.0	5.6m x 100.0	80.0										
6.0	100.0	77.0	100.0	78.5	6.1m x 100.0	80.0	6.6m x 100.0	80.0						
7.0	100.0	73.5	100.0	76.0	100.0	77.5	100.0	79.0	7.2m x 97.2	80.0	7.7m x 91.8	80.0		
8.0	91.3	70.0	91.1	73.0	91.0	75.5	90.9	77.0	90.1	78.5	88.5	79.5	8.2m x 86.1	80.0
9.0	81.6	66.5	81.4	70.0	81.2	73.0	81.1	74.5	80.4	76.5	79.8	77.5	79.2	78.5
10.0	73.7	63.0	73.5	67.0	73.3	70.0	73.2	72.5	72.8	74.5	72.5	76.0	72.2	77.0
12.0	60.5	55.5	60.3	61.0	60.1	65.0	60.0	68.0	59.9	70.5	59.8	72.0	59.7	73.5
14.0	49.9	47.5	49.7	54.5	49.5	59.5	49.4	63.5	49.3	66.0	49.2	68.5	49.1	70.5
16.0	42.3	37.5	42.1	47.5	42.0	54.0	41.9	58.5	41.8	62.0	41.7	64.5	41.6	67.0
18.0	17.2m x 38.7	30.0	36.2	39.5	36.0	47.5	35.9	53.0	35.8	57.5	35.7	60.5	35.6	63.5
20.0			19.8m x 31.8	30.0	31.2	40.5	31.1	47.5	31.0	52.5	30.8	56.5	30.7	59.5
22.0					27.4	32.0	27.3	41.5	27.2	47.5	27.1	52.5	27.0	56.0
24.0					22.4m x 26.8	30.0	24.2	33.5	24.1	42.0	24.0	47.5	23.9	52.0
26.0							25.0m x 22.9	30.0	21.6	36.0	21.5	42.5	21.4	47.5
28.0									27.6m x 19.9	30.0	19.4	37.0	19.3	43.0
30.0											17.5	31.0	17.5	38.5
32.0											30.2m x 17.4	30.0	16.0	32.5
34.0													32.8m x 15.4	30.0

Notes

- Working radius is horizontal distance from center of rotation to a vertical line through the center of gravity of the load.
- The weight of hook block and other lifting devices must be considered to be a part of the loads.

for main boom	for 1m aux. jib
100ton hook block.....1.40ton	13.5ton hook block.....0.60ton
60ton hook block.....1.20ton	
30ton hook block.....1.00ton	
- Do not exceed 3° of trim angle pontoon on loaded condition.
- Depending on the number of part lines, rated lifting load in limited as follows

1-part line.....up to 13.5ton	5-part line.....up to 62.5ton
2-part line.....up to 25.0ton	6-part line.....up to 75.0ton
3-part line.....up to 37.5ton	7-part line.....up to 87.5ton
4-part line.....up to 50.0ton	8-part line.....up to 100ton
- When 1m aux. jib in fitted actual loads that can be lifted with main hook blocks should be reduced 0.8ton from the above chart (the weight includes aux. hook block).
- The boom length that can be used in bucket operation by means of clamshell etc. is up to 27m.
- The rated lifting load is up to 12.5ton in bucket operation. The total of bucket weight and loads can not exceed this value.

■ 1m aux. jib rated lifting loads

(Unit:metric ton)

Boom length (m) Working radius (m)	18	21	24	27	30	33	36
5.0	5.9m x 13.5						
6.0	13.5	6.4m x 13.5	7.0m x 13.5				
7.0	13.5	13.5	13.5	7.5m x 13.5	8.0m x 13.5		
8.0	13.5	13.5	13.5	13.5	13.5	8.5m x 13.5	9.0m x 13.5
9.0	13.5	13.5	13.5	13.5	13.5	13.5	13.5
10.0	13.5	13.5	13.5	13.5	13.5	13.5	13.5
12.0	13.5	13.5	13.5	13.5	13.5	13.5	13.5
14.0	13.5	13.5	13.5	13.5	13.5	13.5	13.5
16.0	13.5	13.5	13.5	13.5	13.5	13.5	13.5
18.0	13.5	13.5	13.5	13.5	13.5	13.5	13.5
20.0	18.8m x 13.5	21.4m x 13.5	13.5	13.5	13.5	13.5	13.5
22.0			13.5	13.5	13.5	13.5	13.5
24.0			24.0m x 13.5	13.5	13.5	13.5	13.5
26.0				26.6m x 13.5	13.5	13.5	13.5
28.0					29.2m x 13.5	13.5	13.5
30.0						13.5	13.5
32.0						31.7m x 13.5	13.5
34.0							34.3m x 13.4

Notes

- Working radius is horizontal distance from center of rotation to a vertical line through the center of gravity of the load.
- When the main hook block is installed, the lifting loads of jib must be reduced by the weight of hook block (main and jib) and other lifting devices.

100ton hook block...1.40ton	30ton hook block...1.00ton
60ton hook block...1.20ton	13.5ton hook block...0.60ton
50ton hook block...1.00ton	
- Do not exceed 3° of trim angle pontoon on loaded condition.
- Bucket operation can not be performed by 1m jib.

Individual masses and outline dimensions

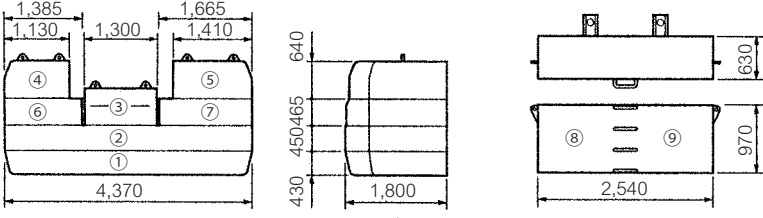
	Main part name	Mass (tons)	Q'ty	Dimensions(m) L x W x H																						
Main body	Main body (without "A" frame, ropes, axles and crawlers)	(31.9)	(1)	7.95 x 3.37 x 3.17																						
	Main body (with "A" frame, and without ropes, axles and crawlers)	(36.2)	(1)	9.60 x 3.37 x 3.32																						
	Main body (with "A" frame, ropes, and axles and without crawlers)	47.3	1	10.17 x 3.37 x 3.33																						
	Crawler	18.9	2	9.18 x 1.07 x 1.37																						
	Counterweight, weight for body	94.0	9	See below.																						
	Counterweight arrangement and dimensions (mm)		 <table border="1" data-bbox="1134 383 1337 638"> <thead> <tr> <th colspan="2">Weight (tons)</th> </tr> </thead> <tbody> <tr><td>①</td><td>18.5</td></tr> <tr><td>②</td><td>18.6</td></tr> <tr><td>③</td><td>9.8</td></tr> <tr><td>④</td><td>7.5</td></tr> <tr><td>⑤</td><td>9.6</td></tr> <tr><td>⑥</td><td>6.2</td></tr> <tr><td>⑦</td><td>7.8</td></tr> <tr><td>⑧</td><td>8.0</td></tr> <tr><td>⑨</td><td>8.0</td></tr> <tr><td>Total</td><td>94.0</td></tr> </tbody> </table>			Weight (tons)		①	18.5	②	18.6	③	9.8	④	7.5	⑤	9.6	⑥	6.2	⑦	7.8	⑧	8.0	⑨	8.0	Total
Weight (tons)																										
①	18.5																									
②	18.6																									
③	9.8																									
④	7.5																									
⑤	9.6																									
⑥	6.2																									
⑦	7.8																									
⑧	8.0																									
⑨	8.0																									
Total	94.0																									
Crane attachment	Inner boom (with boom limit stop)	3.1	1	7.75 x 2.65 x 2.4																						
	Outer boom (with pendant rope)	3.4	1	11.3 x 2.45 x 2.35																						
	3m insert boom (with pendant rope)	0.85	As required	3.15 x 2.45 x 2.35																						
	6m insert boom (with pendant rope)	1.35	As required	6.15 x 2.45 x 2.35																						
	9m insert boom (with pendant rope)	1.8	As required	9.15 x 2.45 x 2.35																						
	Equalizer	0.8	1	2.27 x 1.14 x 0.36																						
	Inner jib (with jib strut pendant rope)	1.1	1	6.95 x 1.35 x 1.05																						
	Outer jib (with pendant rope)	0.5	1	6.85 x 1.07 x 1.05																						
	1m aux. jib	0.35	1	1.99 x 0.64 x 0.4																						
	6m insert jib (with pendant rope)	0.25	As required	6.1 x 0.98 x 1.05																						
	200ton hook	2.7	1	0.85 x 2.36 x 1.01																						
	150ton hook	2.4	1	0.85 x 2.21 x 0.82																						
	100ton hook	1.4	1	0.73 x 1.97 x 0.54																						
	60ton hook	1.2	1	0.8 x 1.77 x 0.5																						
13.5ton hook (shared with luffing jib)	0.6	1	0.46 x 1.52 x 0.46																							
Luffing attachment	Inner post (with inner post yoke and stabilizer)	5.3	1	7.75 x 2.65 x 2.4																						
	Tower top	2.9	1	4.86 x 3.02 x 2.35																						
	3m insert post (shared with 3m insert boom)	0.95	As required	3.15 x 2.45 x 2.35																						
	6m insert post (shared with 6m insert boom)	1.50	As required	6.15 x 2.45 x 2.35																						
	9m insert post (shared with 9m insert boom)	2.10	As required	9.15 x 2.45 x 2.35																						
	Middle equalizer	0.3	1	1.21 x 0.76 x 0.33																						
	Strut	2.5	set	7.42 x 2.07 x 1.15																						
	Tower inner jib (with jib limit stop)	1.82	1	9.15 x 2.57 x 1.5																						
	Tower outer jib (with pendant rope)	1.1	1	9.4 x 2.1 x 1.61																						
	3m tower insert jib (with pendant rope)	0.32	As required	3.1 x 1.6 x 1.5																						
	6m tower insert jib (with pendant rope)	0.54	As required	6.1 x 1.6 x 1.5																						
	9m tower insert jib (with pendant rope)	0.74	As required	9.1 x 1.6 x 1.5																						
	50ton hook (for post operations)	1.0	1	0.8 x 1.9 x 0.43																						
25ton hook (shared with post and jib operations)	1.0	1	0.8 x 1.61 x 0.35																							

◆ Diagrams shown have been drawn for catalog purposes and may differ from actual products.

◆ Specifications are subject to change without notice due to technical improvements or modifications.

OPERATOR ORIENTED DESIGN ENSURES SAFE AND EFFECTIVE OPERATION OF GREAT 200-TON

Highest rope speeds in this class 110 meter/minute Load Hoist/Lowering



● Powerful Swing

Powerful double-hydraulic-motor for swing motion is independent from all other operations.



● Full Power-Efficient Hydraulic Control System

Two variable displacement pumps and one gear pump incorporated into engine provide the most effective usage of engine output. Hydraulic flow and pressures are automatically regulated to deliver high flow and low pressure for lighter loads, low flow and high pressure under heavy loading.

Hydraulic Motors to drive main drum, auxiliary drum, the third drum and boom hoist/lowering drum are independently controlled to match each operating speeds. (The third drum is optional for application other than the luffing jib crane)

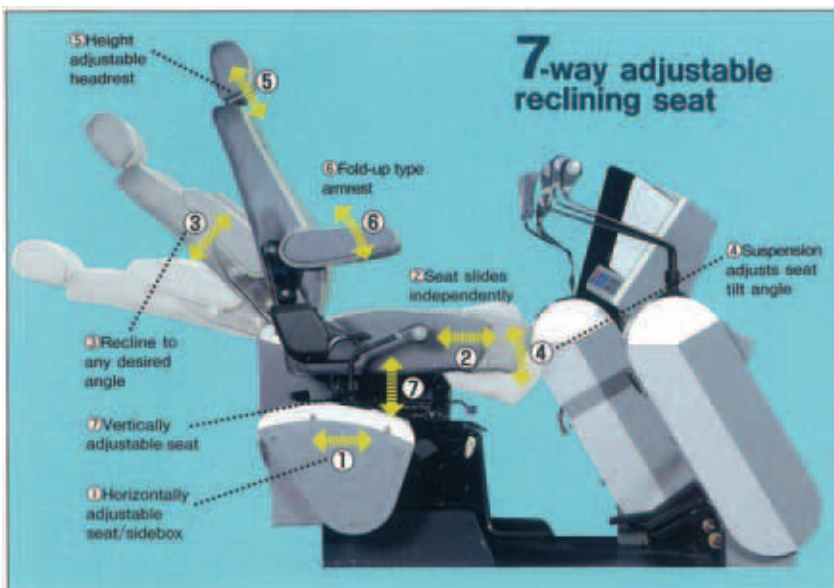

● Dial system controller

Hydraulic pump delivery volume is controlled in conjunction with engine speed supplemented by and independent swash-plate angle control dial. The device provides easy, accurate and precise inching work.



● Wide visibility and deluxe control stands

Dazzle free front glass, radio, intermittent windshield wiper, sunshade, stowbox are standard equipped. Levers, pedals, switches are logically located for safe and easy operation. Engine throttle switch is integrated on swing lever grip. Winch mode switch (select foot or automatic) is located on main and aux. hoist levers.





CCH2000-5 Luffing Jib Crane



IHI Construction Machinery Limited

Kishi-Tokai Bldg.,8-4-4, Nishikamata, Ota-ku, Tokyo 144-8577, JAPAN
Phone: 81-3-5714-8844 Fax: 81-3-5714-8840, 8841

Specifications are subject to change without notice due to technical improvements or modifications.
Distributed by

