

HD1638-R5

Progress to the Next Stage

KATO

HYDRAULIC EXCAVATOR

REGZM

HYDRAULIC EXCAVATOR

HD1638-R5

Bucket capacity : 1.6m³-1.8m³ (ISO)
Engine output : 183kW / 2,150min⁻¹ (ISO Net)
Operating weight : 36,000kg

EQUIPMENT

- New color monitor display (APC300)
- Auto-slow, one touch slow
- Working mode selector (APC300)
- 2 speed modes for traveling
- Automatic transmission for traveling
- Pull up front window
- 6 points viscous dumping cab
- Double slide operation seat
- Seat suspension adjustable to operator's weight
- Intermittent windshield wiper
- Emergency exit rear window
- Cabin light
- 2 std working lights
(Slewing table right side and boom left side)
- Boom / Arm Anti-drift valve
- High power of digging force
- Slewing anti-counter action
- Automatic parking brake (slewing)
- Automatic parking brake (traveling)
- Service port (1 spool)
- Rear view mirror (right side)
- Full track guard
- 2 holes front window washer
- Automatic air conditioner (pressurized)
- Hot & cool box
- AM / FM radio
- 13 cm dual corn speaker x2
- Air cleaner double element
- Pre-cleaner
- Tool set
- Arm protection plate
- Seat-belt
- 2 ways option piping for breaker & crusher (option)
- Fire extinguisher

● Contact for enquiry:

NOTE : Illustrations may include optional equipment. KATO products and specifications are subject to improvements and changes without notice. Mentioned figures are approximate.

KATO WORKS(CHINA)LTD.

NO.8 Huasheng South Road, Huayang Industrial Park,
Zhoushi Town, Kunshan City, Jiangsu Province, China
Tel. :0512-57065058
Fax. :0512-57065052

KATO WORKS CO.,LTD.

9-37, Higashi-ohi 1-chome, Shinagawa-ku,
Tokyo 140-0011, Japan.
Tel. :Head Office Tokyo(03)3458-1111
Overseas Marketing Department Tokyo(03)3458-1115
Fax. :Tokyo(03)3458-1163



**A high-grade excavator
looking at the future**

REGZM

HD1638-R5

- **Reliable Mitsubishi 6M60-TL engine is mounted**
(GB20891-2014)
- **The APC300 system has the excellent operability**
Through switching between the three modes, choose the most optimum mode of operation according to different working conditions.
- **New generation high efficiency work**
New type control valve · New hydraulic pump installed
Large diameter hydraulic piping · Pathway optimization greatly reduces pressure loss
- **The fuel filtration system is enhanced**
- **Efficient machine construction and configuration design making the maintenance and safety better**
Improve engine oil filter and fuel filter configurations.
Equipped with battery disconnect switch.
- **Adopt Heavy-duty Bucket & side link**
- **Boom raising priority function**
Select boom raising priority switch, to operate the boom more easily. (Boom moves faster and stronger)



Better maintainability and safety Establish a long-term stability of the machine

▲ Adopt reinforced arm, and side link
 ● Adopt slewing table protective guard
 ● Heavier counterweight
 ▲ Adopt large diameter hydraulic piping
 ▲ Adopt full track guard
 ▼ Grease gun holder ▼ Washer tank
 ▲ Heavy-duty bucket
 ● Reinforced track shoe
 ▲ Engine oil filter configuration is more efficient
 The filter can be replaced without climbing through under the body with better maintainability and safety.
 ▲ Easier maintenance of swing motor
 ● Filling port with extension pipe
 ● Drain pipe diameter increase
 ● Top surface remote lubrication grease port
 ▲ Including new control valve, increased the diameter of hydraulic piping diameter
 ▲ The fuel tank is equipped with a discharge cock
 ▲ Fuel filter
 By arranging the triple filters in the same position to improve the efficiency of replacement. Easy to access and improve safety.
 ▲ Equipped with battery disconnect switch
 ▲ New air pre-filter that does not require the special maintenance
 ● The fuel tank is increased to 660L

Common rail electronic control fuel system further enhances fuel efficiency More energy efficient and more environmentally friendly

High efficiency
Low fuel consumption
Low noise
Mitsubishi 6M60-TL engine

- High output power engine with intercooler and turbocharger
 - Max. output power : **183kW / 2,150min⁻¹** (ISO Net)
 - Max. torque : **824N·m / 1,800min⁻¹** (ISO Net)
 - Fuel consumption : **215g / kW·h**

Latest APC300 with various functions



- P Mode**
Pro mode established both power and good response.
- A Mode**
All-round mode is ideal for general operation.
- E Mode**
ECO mode for economical works.
- Auto-slow mode**
Auto-slow mode controls the engine to ideal engine speed automatically and save the fuel consumption.
- Able to set maintenance term for filter and oil.
- Hour meter function is adopted.
- Adopt "P mode" (Pro Mode). P, A and E mode operation method are selectable.
- Emergency backup switch is equipped in case of APC malfunction.

◀ Initial confirmation screen
 ◀ When the monitor fails
 ◀ When engine emergency stop switch is operated
 ▲ Boom up priority switch
 ● New Seat



Technical Specifications

ENGINE

Model..... Mitsubishi 6M60-TL,
4 cycle intercooler turbo
charged diesel engine
Number of cylinders..... 6
Bore & Stroke..... 118mm×115mm
Total displacement..... 7.54 L
Rated output..... 183kW/2,150min⁻¹
(ISO Net)
Max. torque..... 824N·m/1,800min⁻¹
(ISO Net)
Compression ratio..... 17.5:1
Combustion system..... Direct injection
Unit fuel consumption..... 215g/kW·h
Cooling system..... Pressurized water
circulated by a
centrifugal pump
with thermostat
Lubrication system..... Pressurized oil fed
by a gear pump
through full-flow
and by-pass
cartridge filter
Starter..... Electric, 24V-5kW
Generator..... Alternator, 24V-50A
Governor..... Electronic variable
speed control
Air cleaner..... Dry type double filter

HYDRAULIC SYSTEM

Pumps..... Double variable piston pump
and gear pump
Max. discharge flow..... 2×307L/min
Max. discharge pressure..... 31.4MPa
Max. discharge pressure
(High power)..... 32.9MPa
Oil filtration..... Full-flow filter with
replaceable element,
a pilot line filter and
suction strainer
Control valves..... 5+4 section multiple
control valves (with one
free service circuit)
Pilot pump..... Gear type
Oil cooler..... Finned tube, forced ventilation
Pressure relief valves..... Primary and
secondary on
each circuit

CAB & CONTROLS

Type..... All weather sound suppressed,
cab mounted on 6 point
viscous mounting.
Right hand levers..... Controls the boom &
bucket
Inner right hand lever
(with foot pedal)..... Controls the right
hand track
Inner left hand lever
(with foot pedal)..... Controls the left
hand track
Left hand lever..... Controls the arm & swing
Pilot control..... Travel, boom, arm, bucket
and swing
Engine throttle..... Electric "Accell dial"
Meter & gauges..... Hour meter, water
temperature and fuel
level
Working lights..... Provided on the boom
left side and right
front cover
Lubrication chart..... Inside of the left side
cover

APC300

- Quick Selection of Working Modes
- P: Professional mode for experienced operator. Established both power and good response
- A: All-round Multi Purpose Mode for all application from precision work to heavy duty work by stroke of operation levers
- E: ECO Mode for economical works
- Color monitor display with back up light
- Engine oil pressure
- Hydraulic oil filter
- Engine preheater
- Hydraulic oil temperature
- Water temperature
- Water level
- Fuel level
- Battery charge
- APC monitor and air cleaner
- Calendar

BOOM, ARM AND BUCKET

Boom cylinders..... 2, double acting
Bore & Stroke..... 150mm×1,450mm
Arm cylinder..... One, double acting
Bore & Stroke..... 170mm×1,840mm
Bucket cylinder..... One, double acting
Bore & Stroke..... 150mm×1,230mm
Lubrication..... Grease nipples, with
centralized greasing for
remote points
Bucket digging force..... 225kN
(High power)..... 236kN
Arm digging force..... 159kN
(High power)..... 167kN

SWING SYSTEM

Drive..... Axial piston motor with shockless
valve and reduction gear.
Brake..... A hydraulic brake that locks
automatically when the swing
control lever is in the neutral
position and a mechanical parking
brake which is applied when the
safety lock lever is pulled
backwards, the engine is turned
off or the swing control lever is in
the neutral position.
Lubrication..... Completely housed and
grease bathed
Max. swing speed..... 10.0min⁻¹
Tail swing radius..... 3,460mm
Min. front swing radius
Standard Boom..... 4,640mm

TRAVEL SYSTEM

Drive..... Independent axial piston motor
with reduction for each side
Brakes..... Independent disk parking brake
for each side, applied
automatically when the travel
levers are in the neutral position.
Track shoes..... 45 each side
Track adjustment..... Grease cylinders
with recoil springs
Lubrication..... Sealed-for-life rollers and
front idlers with floating seals
Travel speed..... High 0~5.2km/h
Low 0~3.9km/h
Gradeability..... 70% (35°)
Max. drawbar pull..... 296kN
Ground clearance..... 500mm
(less grouser bar)
Track length..... 4,670mm

SERVICE DATA

Fuel tank..... 660 L
Cooling system..... 45 L
Engine oil..... 33 L
Track drives..... 2×9.5 L
Revolving mechanism..... 10.5 L
Hydraulic oil tank
(level)..... 200 L
(system)..... 405 L
In standard figure, with the 3.14m arm,
600mm grouser shoes and 1.6m² (ISO),
bucket.
Operating weight..... 36,000kg
Ground pressure..... 72kPa

Working Ranges

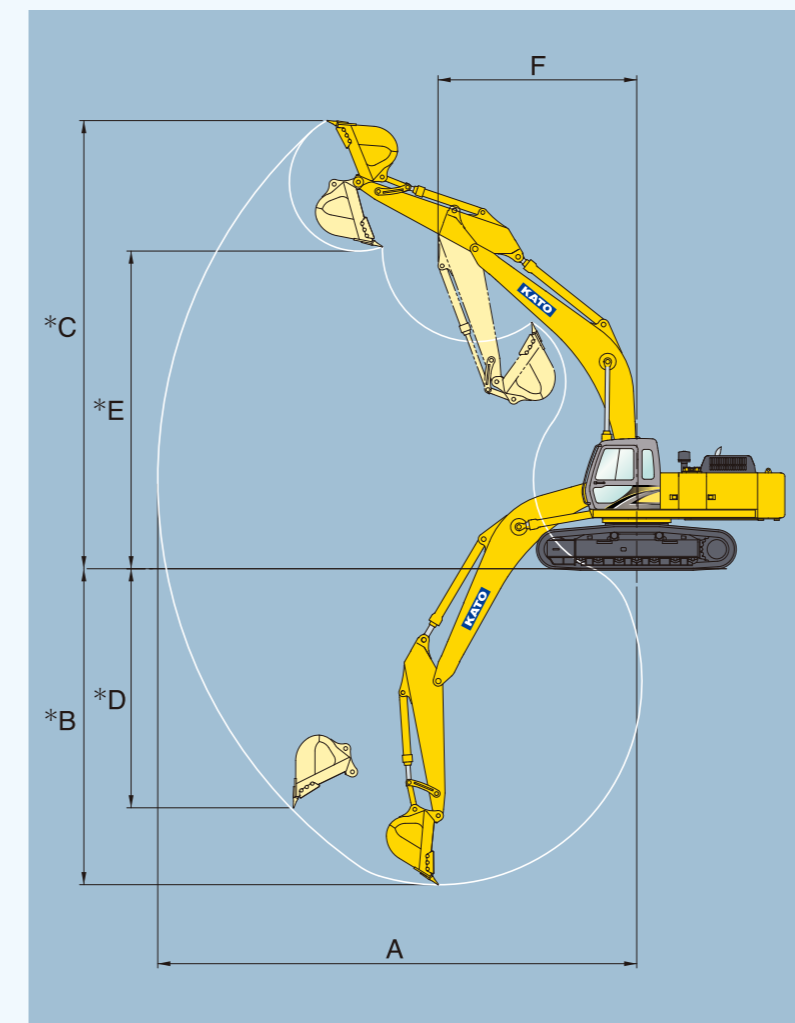

Unit: mm

Range	Arm	Reinforced arm 3.14m
A : Maximum digging radius		11,190
* B : Maximum digging depth		7,380
* C : Maximum digging height		10,470
* D : Maximum vertical wall		5,590
* E : Maximum dumping height		7,420
F : Min. swing radius		4,640

* Less grouser bar

Bucket

Type of bucket		Backhoe bucket	
Bucket capacity	m ³ , ISO	1.6 (Heavy-duty)	1.8
Bucket width	W/O side cutters	mm 1,350	1,660
	with side cutters	mm 1,410	—
Number of bucket teeth		5	6
Shape of bucket			
Reinforced arm		●	▲

● General purpose ▲ Light work ○ Blue colored area means standard.

Track Shoes

Type of shoes		Grouser shoe
Type of shoes		
Specifications for main body	Shoe width	mm 600
	Operating weight	kg 36,000
	Overall height	mm 3,480
	Ground clearance	mm *500
	Crawler overall length	mm 4,670
	Distance between shoe edge of both side	mm 3,190
	Ground pressure	kPa
kgf/cm ²		0.73

Ground pressure when equip standard bucket and arm.
* Less grouser bar
○ Blue colored area means standard.

Dimension : HD1638-R5

(Unit: mm)

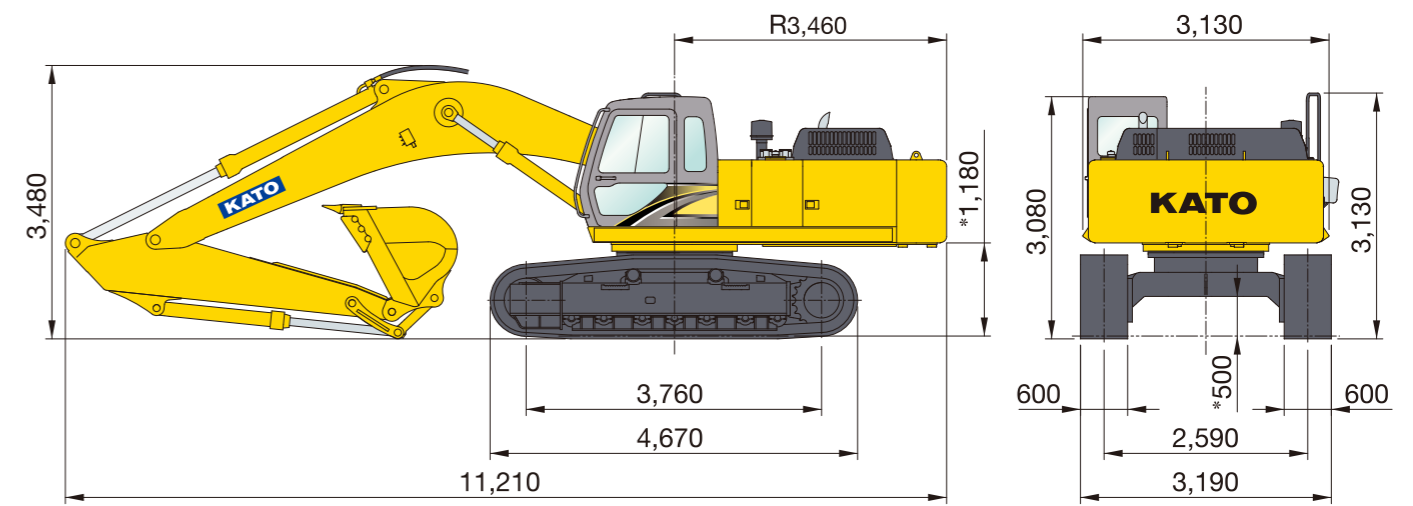

* Less grouser bar