

# Innovations For The Future

Eco & Tough



## Dimensions

HD308USV

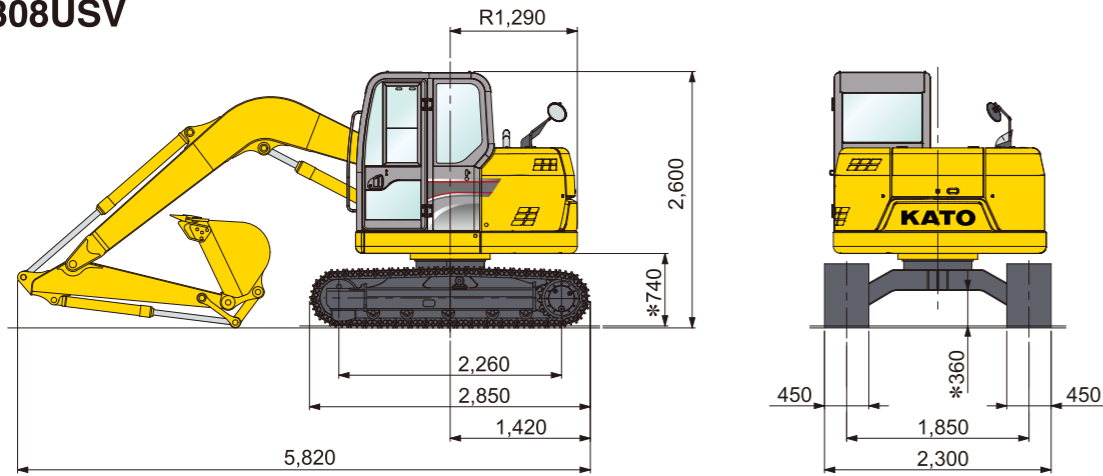

\*Less grouser bar

Address inquiries to :

NOTE : Illustrations may include optional equipment. KATO products and specifications are subject to improvements and changes without notice.



# KATO

QUALITY & EXPERIENCE  
SINCE 1895

## KATO WORKS CO.,LTD.

9-37, Higashi-ohi 1-chome, Shinagawa-ku, Tokyo 140-0011 Japan.

Tel. : Head Office Tokyo(03)3458-1111

Overseas Marketing Department Tokyo(03)3458-1115

Fax. : Tokyo(03)3458-1163

URL <http://www.kato-works.co.jp>

# KATO

# REGZM

FULLY HYDRAULIC EXCAVATOR

## HD308USV

Bucket capacity: 0.12m<sup>3</sup>-0.34m<sup>3</sup>(ISO)

Engine output: 40.0kW / 2,000min<sup>-1</sup> (ISO Net)

Operating weight: 7,300kg





# **REGZM**

## **HD 308 USV**

***It is a word of ACTIVE MACHINE  
with 5 essential design features***

- || User friendly design
- || Environmentally cautious design
- || Lower fuel consumption
- || Easy Maintenance
- || Robotic shape design





# Easier Maintenance



- Gathered APC Electric Equipment
- Parallel established Radiator & Oil Cooler Core

Gathered Filters (Fuel filter, Pilot filter)

Maintenance accessibility is improved. Gathered filters and parallel established radiator & oil cooler through Wide Opening Tail supports easy maintenance.



### Improved Stability

Increased tail radius and new shaped counter weight improve stability.  
Tail Slewing Radius: 1290mm  
(With Optional Weight): 1370mm



### Clearance for Feet

Compact established pedals & levers offers wider space for feet.



### New APC (APC150)

Adoption of new APC system (APC150) offers easier operations and maintenance.

- Quick selection of working modes
- Color monitor display and Back-light at touch switches
- 12 maintenance information available

# Technical Specifications

## ENGINE

Model..... ISUZU 4LE2X  
4 cycle intercooler turbo charged diesel engine  
Number of cylinders..... 4  
Bore & Stroke..... 85.0mm×96.0mm  
Total displacement..... 2.179 L  
Rated output..... 40.0kW/2,000min<sup>-1</sup> (ISO Net)  
Max. torque..... 209N·m/1,500min<sup>-1</sup> (ISO Net)  
Compression ratio..... 18.3:1  
Combustion system..... Direct injection  
Specific fuel consumption..... 234±7g/kW-hour  
Cooling system..... Pressurized water circulated by a centrifugal pump with thermostat  
Lubrication system..... Pressurized oil fed by a gear pump through full-flow and by-pass cartridge filter  
Starter..... Electric, 24V-3.2kW  
Generator..... Alternator, 24V-50A  
Governor..... Mechanical  
Air cleaner..... Dry type filter

## HYDRAULIC SYSTEM

Pumps..... Double variable piston pump and gear pump  
Max. discharge flow..... 2×74.0L/min  
Max. discharge pressure..... 29.4MPa  
Max. discharge pressure (travel circuit only)..... 31.4MPa  
Oil filtration..... Full-flow filter with replaceable element, a pilot line filter and suction strainer  
Control valves..... 5+4 section multiple control valves (with one free service circuit)  
Pilot pump..... Gear type  
Oil cooler..... Finned tube, forced ventilation  
Pressure relief valves..... Primary and secondary on each circuit

## CAB & CONTROLS

Type.....All weather sound suppressed, cab mounted on 4 point viscous mounting.  
Right hand levers.....Controls the boom & bucket  
Inner right hand lever (with foot pedal)..... Controls the right hand track

Inner left hand lever (with foot pedal)..... Controls the left hand track  
Left hand lever..... Controls the arm & swing  
Pilot control..... Travel, boom, arm, bucket and swing  
Engine throttle..... Electric "Accell dial"  
Meter & gauges..... Hour meter, water temperature and fuel level  
Working lights..... Provided on the boom left side and right front cover  
Lubrication chart..... Inside of the right front side cover

## APC150

- Quick Selection of Working Modes
- A: All-around Multi Purpose Mode for all application from precision work to heavy duty work by stroke of operation levers
- E: ECO Mode for economical works
- Color monitor display with back up light
- Engine oil pressure
- Hydraulic oil filter
- Engine preheater
- Hydraulic oil temperature
- Water temperature
- Water level
- Fuel level
- Battery charge
- APC monitor and air cleaner
- Fuel water level
- Calendar

## BOOM, ARM AND BUCKET

Boom cylinders..... One, double acting  
Bore & Stroke..... 105mm×960mm  
Arm cylinder..... One, double acting  
Bore & Stroke..... 95mm×920mm  
Bucket cylinder..... One, double acting  
Bore & Stroke..... 85mm×745mm  
Lubrication..... Grease nipples, with centralized greasing for remote points  
Bucket digging force..... 61.4kN (6,300kgf)  
Arm digging force..... 42.2kN (4,300kgf)

## SWING SYSTEM

Drive..... Axial piston motor with shockless valve and reduction gear.  
Brake..... A hydraulic brake that locks automatically when the swing control lever is in the neutral position and a mechanical parking brake which is applied when the safety lock lever is pulled backwards, the engine is turned off or the swing control lever is in the neutral position.  
Lubrication..... Completely housed and grease bathed  
Max. swing speed..... 10.0min<sup>-1</sup>  
Tail swing radius..... 1,290mm  
Min. front swing radius..... 1,630mm

## TRAVEL SYSTEM

Drive..... Independent axial piston motor with reduction for each side  
Brakes..... Independent disk parking brake for each side, applied automatically when the travel levers are in the neutral position.  
Track shoes..... 39 each side  
Track adjustment..... Grease cylinders with recoil springs  
Lubrication..... Sealed-for-life rollers and front idlers with floating seals  
Travel speed..... High 0~5.0km/h  
Low 0~3.2km/h  
Gradeability..... 70% (35°)  
Max. drawbar pull..... 66.9kN  
Ground clearance..... 360mm (less grouser bar)  
Track length..... 2,850mm

## SERVICE DATA

Fuel tank..... 120 L  
Cooling system..... 11 L  
Engine oil..... 10.7 L  
Track drives..... 2×1.3 L  
Hydraulic oil tank (level)..... 51 L (system)..... 98 L  
In standard figure, with the 1.62m arm, 450mm grouser shoes and 0.28m<sup>3</sup> (ISO), bucket.  
Operating weight..... 7,300kg  
Ground pressure..... 32kPa



# Working Ranges

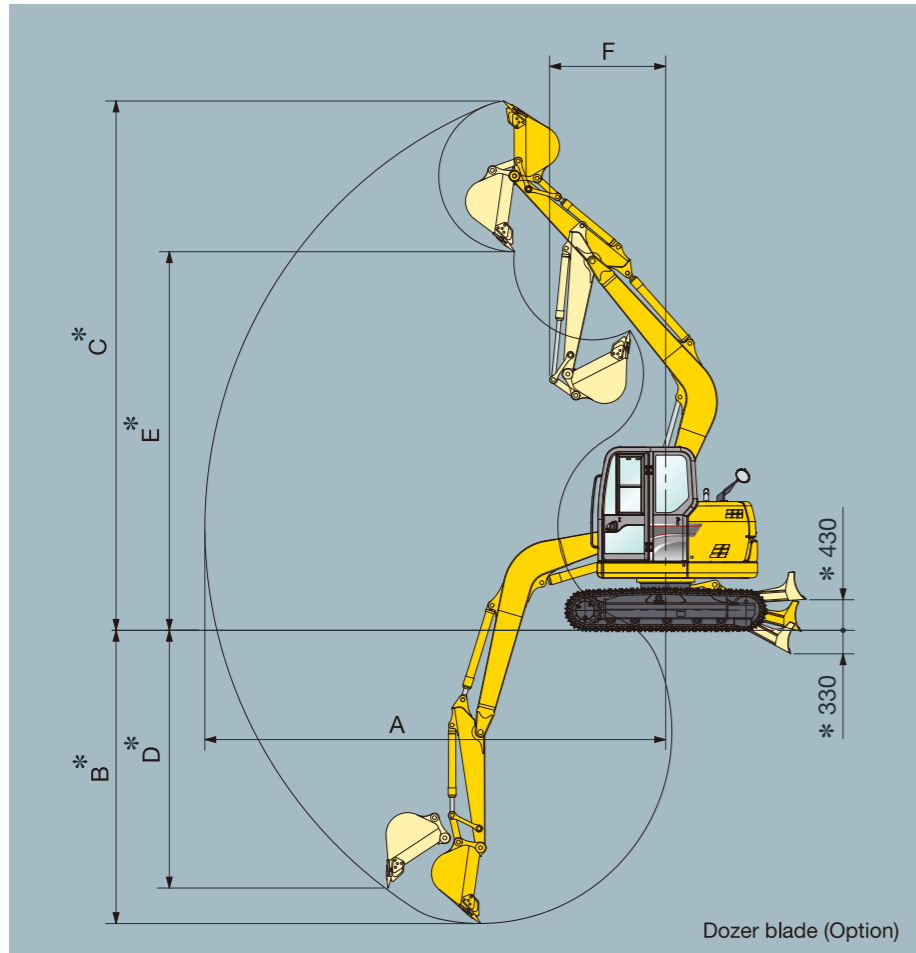

Range	Arm	Unit : mm	
		STD (1.62m)	Long Arm (2.07m)
A : Max. digging radius		6,470	6,910
*B : Max. digging depth		4,120	4,570
*C : Max. digging height		7,430	7,800
*D : Max. vertical wall		3,620	4,140
*E : Max. dumping height		5,320	5,680
F : Min. swing radius		1,630	2,010

\* Less grouser bar.

## Bucket

Type of bucket		Backhoe bucket					Slope forming bucket
Bucket capacity	m <sup>3</sup> , ISO	0.12	0.16	0.22	0.28	0.34	-
Bucket width	W/O side cutters, mm	370	440	555	650	770	1,400 × 800
	with side cutters, mm	480	555	670	770	890	
Bucket weight	kg	170	190	210	230	250	305
Number of bucket teeth		3	3	3	4	4	-
Shape of bucket							
Standard boom +	Standard arm	●	●	●	●	▲	●
	Long arm	●	●	●	▲	×	▲▲
	Extension arm	●	▲	×	×	×	

● General purpose ▲ Light work × Unusable ○ Yellow colored area means standard.

## Track Shoes

Type of shoes		Pat crawler	Grouser shoe		Flat shoe	Triangle shoe	
Shoe width	mm	450	450	600	450	600	700
Overall width	mm	2,300	2,300	2,450	2,300	2,450	2,550
Ground pressure	kPa	32 (0.33)	32 (0.33)	25 (0.25)	34 (0.34)	25 (0.25)	22 (0.22)
Net weight change	kg	±0	S.T.D	+120	+340	+260	+330

○ Yellow colored area means standard.

# Lifting Capacities

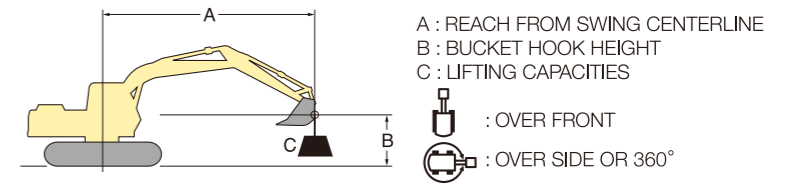

**HD308USV** BOOM: 3.83m, ARM: 1.62m, BUCKET: 0.28m<sup>3</sup> (230kg), SHOE WIDTH: 450mm, COUNTERWEIGHT: 1,060kg Unit: 1,000kg

LOAD POINT HEIGHT B (m)	OUTREACH A (m)								RATING AT MAXIMUM REACH		
	2.00		3.00		4.00		5.00		m	m	m
	○	⊗	○	⊗	○	⊗	○	⊗			
5.00			*1.35	*1.35							
4.00			*1.56	*1.56	*1.48	*1.48					
3.00	*2.85	*2.85	*2.03	*2.03	*1.70	1.52	1.26	1.02	1.09	0.88	5.39
2.00			*2.64	2.28	1.77	1.43	1.22	0.98	1.00	0.80	5.58
1.00			2.68	2.10	1.68	1.34	1.17	0.94	0.97	0.78	5.58
0.00	*3.06	*3.06	2.58	2.01	1.62	1.29	1.14	0.91	1.01	0.80	5.40
-1.00	*3.10	*3.10	2.56	1.99	1.59	1.26	1.13	0.90	1.13	0.90	5.01
-2.00	*3.09	*3.09	2.59	2.02	1.61	1.28			1.42	1.13	4.36
-3.00	*3.20	*3.20	*2.24	2.11					*1.98	1.83	3.29

**HD308USV** BOOM: 3.83m, ARM: 2.07m, BUCKET: 0.22m<sup>3</sup> (210kg), SHOE WIDTH: 450mm, COUNTERWEIGHT: 1,060kg Unit: 1,000kg

LOAD POINT HEIGHT B (m)	OUTREACH A (m)								RATING AT MAXIMUM REACH				
	2.00		3.00		4.00		5.00		6.00		m	m	m
	○	⊗	○	⊗	○	⊗	○	⊗	○	⊗			
6.00													
5.00					*1.18	*1.18							
4.00					*1.27	*1.27	*1.29	1.08					
3.00			*1.69	*1.69	*1.49	*1.49	1.29	1.05			0.94	0.76	
2.00	*3.72	*3.72	*2.33	*2.33	*1.80	1.46	1.23	1.00	0.89	0.71	0.87	0.69	
1.00	*2.53	*2.53	2.73	2.15	1.70	1.36	1.18	0.95	0.86	0.68	0.85	0.67	
0.00	*2.92	*2.92	2.60	2.03	1.62	1.29	1.14	0.90			0.87	0.69	
-1.00	*3.02	*3.02	2.54	1.98	1.58	1.25	1.11	0.88			0.95	0.75	
-2.00	*3.07	*3.07	2.55	1.98	1.58	1.25					1.14	0.90	
-3.00	*3.28	*3.28	2.61	2.04	1.63	1.30					1.60	1.27	

- NOTE : 1. Lifting capacities are based on ISO 10567.  
 2. Lifting capacities shown do not exceed 87% of machine hydraulic capacity or 75% of minimum tipping load.  
 3. Capacities marked with an asterisk (\*) are limited by hydraulic capacities.  
 4. Lifting capacities are based on machine standing on firm, uniform supporting surface. User must make allowances for job conditions such as soft or uneven ground.  
 5. Lifting capacities shown should not be exceeded. Weight of all lifting accessories must be deducted from the above lifting capacities.  
 6. Capacities apply only to the machine as originally manufactured and equipped by KATO WORKS CO., LTD.  
 7. The operator should be fully acquainted with the Operation Manual before operating the machine.

## Standard Equipment

- COLOR MONITOR DISPLAY (APC150)
- SEAT-BELT
- AUTOMATIC AIR CONDITIONER (PRESSURIZED)
- INTERMITTENT WINDSHIELD WIPER
- EMERGENCY ESCAPE HAMMER
- AM/FM RADIO (2 SPEAKERS)
- DUAL CORN SPEAKER X2
- CABIN LIGHT
- 3 STD WORKING LIGHTS (FRONT RIGHT SIDE, BOOM-L, CAB-L)
- TAIL VIEW MIRROR
- WORKING MODE SELECTOR (APC150)
- AUTO-SLOW, ONE TOUCH SLOW
- AUTOMATIC PARKING BRAKE (SLEWING TABLE)
- AUTOMATIC PARKING BRAKE (TRAVELING)
- SERVICE PORT (1 SPOOL)
- ENTRY SYSTEM

## Optional Equipment

- OPTIONAL WORKING LIGHT (BOOM-R)
- OPTIONAL WORKING LIGHT (CAB-L)
- UNDER COVER SLEWING TABLE (THICKER)
- OPTION PIPING
- BOOSTING CIRCUIT FOR CRUSHER
- MULTI-LEVER
- WINDSHIELD HALF SIZE GUARD
- WINDSHIELD FULL SIZE GUARD
- CABIN GUARD
- REAR VIEW MIRROR-R
- REAR VIEW MIRROR-L
- ELECTRIC HORN
- FLUSHER SLEWING
- BUZZER TRAVELING
- ELECTRIC REFUELING PUMP
- FIRE EXTINGUISHER
- AIR CLEANER DOUBLE ELEMENT
- HIGH PERFORMANCE FUEL FILTER
- HOSE RUPTURE VALVE (FOR BOOM CYLINDERS)
- HOSE RUPTURE VALVE (FOR ARM CYLINDER)
- TRACK GUARD (1 PCS EACH SIDE)
- TRACK GUARD (2 PCS EACH SIDE)
- OPTIONAL WEIGHT (+500kg)